

KWIK-WALL... One Source for Wall Systems.

KWIK-WALL's 3000 Series - Steel Panel operable wall systems answer the challenge for space division needs posed by multi-purpose room layouts. Years of continuing research and development have produced many outstanding features!

KWIK-WALL's Model 3050 Electric Wall Systems are operated between the stacking location and installed position by an electric operator, which connects to the lead panel by a roller chain. Individual panels are hinged together to form a continuous panel train. The 3000 Series - Steel Panel construction features panels that are 3⁵/₈" [92] thick, manufactured of a durable roll-formed steel frame and standard steel skins for maximum durability and sound control.

SOUND CONTROL...

KWIK-WALL's 3000 Series - Steel Panel is a complete line of acoustically rated wall systems that are designed and manufactured to meet the most demanding sound control requirements. Sound Transmission Class (STC) ratings from 43 STC to 55 STC have been tested and certified in an independent acoustical laboratory in accordance with ASTM E 90 and ASTM E 413 test procedures. The STC ratings represent a single number expression of the effectiveness of an operable wall in preventing the passage of transmitted sound in the range* of 125 Hz to 4,000 Hz. For assistance with designing room division applications using Operable, Glass or Accordion wall systems, please contact your local KWIK-WALL distributor.

*The average human ear has an audibility range from 125 Hz to 4,000 Hz. Levels in excess of 65 dB to 70 dB are generally too loud for ordinary speech communication. When the sound pressure exceeds 120 dB, it normally passes the threshold of pain.

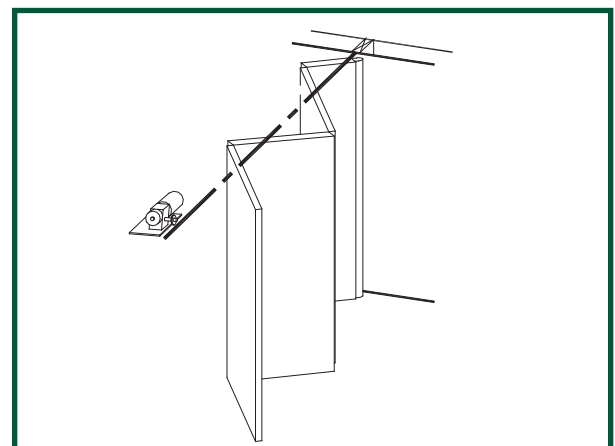

1.01 WORK INCLUDED

- A. Operable Wall System shall be furnished, installed and serviced by KWIK-WALL's authorized distributor, in compliance with the architectural drawings and specifications contained herein.

1.02 RELATED WORK

- A. Structural Support: Structural support system required for suspending the operable wall shall be designed, installed and pre-punched by others, in accordance with ASTM E 557 and KWIK-WALL's shop drawings.
- B. Insulation: Sound insulation and baffles for the plenum area above the track system, under the permanent floor, inside air ducts passing over or around the operable wall, and in permanent walls adjoining the operable wall system shall be by others, in accordance with ASTM E 557.
- C. Opening Preparation: Proper and complete preparation of the operable wall system opening shall be by others in accordance with ASTM E 557, and shall include floor leveling; plumbness of adjoining permanent walls; substrate and / or ceiling tile enclosures for the track system; and the painting and finishing of trim and other materials adjoining the head and jamb areas of the operable wall.

1.03 SYSTEM DESCRIPTION

- A. The operable wall system shall consist of Continuously Hinged panels that are electrically operated, featuring panels hinged together in a continuous panel train.
- B. The operable wall system shall consist of acoustically rated panels tested in accordance with ASTM E 90 and ASTM E 413 test procedures, and shall have achieved a STC rating as specified herein (see "Acoustical Performance" article listed under Part 2 - Products).

1.04 QUALITY ASSURANCE

- A. The operable wall shall have been tested in an independent acoustical testing laboratory in accordance with ASTM E 90 and ASTM E 413 test procedures.
- B. The operable wall panel construction and finish materials shall consist of Class A rated materials in accordance with ASTM E 84.
- C. The operable wall shall be installed by KWIK-WALL's authorized distributor in accordance with ASTM E 557.

1.05 REFERENCES

- A. ASTM E 90: Laboratory Measurement of Airborne-Sound Transmission Loss of Building Partitions.
- B. ASTM E 413: Determination of Sound Transmission Class (STC).
- C. ASTM E 557: Architectural Application and Installation of Operable Partitions.
- D. ASTM E 84: Surface Burning Characteristics of Building Materials.
- E. ASTM A 653: Specification for General Requirements for Steel Sheet, Alloy-Coated (Galvannealed) by the Hot Dip Process.
- F. ASTM C 423: Standard Test Method for Sound Absorption and Sound Absorption Coefficients by the Reverberation Room Method.

- G. CCC-W-408A-D: Federal Specification which applies to Vinyl Coated Wall Coverings.
- H. CFFA-W-101-B: Chemical Fabrics and Film Association Quality Standard for Vinyl Coated Fabric Wall Coverings.

1.06 SUBMITTALS

- A. KWIK-WALL shall provide written technical information and related detail drawings, which demonstrate that the products comply with contract documents for each type of operable partition specified.
- B. KWIK-WALL shall provide detailed engineering drawings featuring track plan, panel elevation, horizontal and vertical details, wiring diagram and beam punching template as required.
- C. KWIK-WALL shall provide written test report of the independent acoustical testing laboratory certifying the attainment of the specified STC rating, upon request.
- D. KWIK-WALL shall provide written instructions specifying the proper operation and maintenance of the operable wall system.
- E. KWIK-WALL shall provide a color selector demonstrating the manufacturer's selections of the specified finish material. Samples shall consist of actual swatches of the specified finish material.

1.07 DELIVERY, STORAGE AND HANDLING

- A. Panels shall be individually wrapped in a protective plastic covering to keep panels clean during delivery, storage and handling.
- B. Panels shall be stored on edge and above the floor on cushioned blocking in a dry and ventilated area, protected from humidity and temperature extremes.

1.08 SEQUENCING / SCHEDULING

- A. Beam Punching: KWIK-WALL shall provide beam punching template drawing detailing the anchor locations for the suspended track system (as required for Drop Rod Mounting), as required for the fabrication and installation of structural overhead support by others.
- B. Track Installation: Scheduling of operable wall track installation shall occur after structural overhead support has been properly and completely fabricated and installed by others.
- C. Panel Installation: Operable wall panel installation shall occur after fixed wall substrate construction is properly and completely installed by others, as required to protect panels from ongoing adjacent construction.

1.09 WARRANTY

- A. KWIK-WALL shall warrant each partition and its component parts to be free from defects in material and workmanship for a period of five (5) years from the date of delivery to the original purchaser, when installed by an authorized KWIK-WALL distributor (see actual warranty on Page 12 for details and limitations).

2.01 ACCEPTABLE MANUFACTURER

A. Operable walls shall be Series 3000, Model 3050 Continuously Hinged / Electric as manufactured by KWIK-WALL Company.

2.02 PANEL CONSTRUCTION

- A. Panel Dimensions: Standard panel dimension shall be a nominal 3⁵/₈" [92] thick.
- B. Panel Frame: Steel frame shall be 16-gauge galvanized steel, which meets or exceeds ASTM A 653 requirements. Frame shall be all-welded construction with steel corner supports and cross-bracing reinforcement. Top horizontal cross brace shall be a minimum 7-gauge structural rectangular steel tube designed to accept a spring-loaded floating carrier. Panel frame shall be Class A rated, fire retardant, non-combustible and non-corrosive in accordance with ASTM E 84.
- C. Panel Skins: Panel skins shall be Class A rated in accordance with ASTM E 84. Panel skin material shall consist of (select):
1. Standard Steel Skins: consisting of minimum 22-gauge tension-leveled galvanized steel, pressure laminated to a structural acoustical backer and mechanically-joined to the steel frame to form a rigid, unitized and structural panel.
 2. Optional Acoustical Substrate: consisting of structural acoustical substrate pressure laminated to both sides of the steel frame to form a rigid, unitized and structural panel.
- D. Panel Hinges: Panel hinges shall be architectural grade, full leaf butt hinges secured directly through the panel frame and into a steel hinge anchor bracket. Bottom hinge shall be located 7'-0" (2.13 m) A.F.F. for partition heights over 16'-0" [4.88].
- E. Panel Weight: Maximum panel weight shall be 5.9 - 12.9 lb./ft.² (29 - 63 kg/m²) depending on STC rating, size and options selected.

2.03 OPERATION

- A. Operation: Operation shall be Continuously Hinged / Electric, consisting of panels hinged together forming a continuous panel train. Panels shall be top-supported by one (1) carrier in each panel, consisting of four (4) permanently lubricated, precision ground ball bearing polished steel wheels riding on a steel tread surface. Panels shall be operated between stacking location and installed position by an electric operator, which connects to lead panel by #50 roller chain. A manual override shall be included in the event of a power failure to allow the wall system to be manually operated.
- B. Drive System: Electric operator shall consist of 1 H.P. (.746 kw), 115 volt, single phase capacitance wound electric motor. Activation of the operator shall be controlled by a two (2) position (low voltage) key switch to arm the system. Control of the operator shall consist of two (2) stations with extend and retract constant-pressure push button switches. Switches shall be low voltage, wired in series, and located on opposite sides and ends of the partition. Electric operator shall include safety devices (limit switches) to automatically shut off the operator at the fully extended and fully retracted position. Operator shall be located at the opposite end of stack area off center to the side of the partition. All electric operator components shall be modularized for easy replacement in the field without removing the surrounding components. Access

panels to the operator unit and return sprockets are required for adjustment and maintenance purposes, as provided by others. Electric operator shall consist of (select):

1. Standard Speed Reducer Drive: consisting of a 50 to 1 ratio worm gear, adjustable clutch and 1 H.P. (.746 kw) electric motor. Speed reducer drive system shall be capable of moving a wall system up to 600 ft.2 (56 m²).
2. Optional Hydraulic Drive: consisting of a hydraulic pressure relief mechanism capable of limiting the closing force of the wall system. Hydraulic drive system shall be operated by a 1 H.P. (.746 kw) electric motor.

2.05 FINISHES

- A. Finish Material Type: Panel finish material shall be Class A (except wood veneer) rated in accordance with ASTM E 84, consisting of (select):
1. Standard Vinyl: consisting of Type I, reinforced vinyl weighing 15 oz./lin. yd. (465 g/lin. m). Standard Vinyl shall meet or exceed CCC-W-408A-D and CFFA-W-101-B quality standards.
 2. Optional Upgrade Vinyl: consisting of Type II, reinforced vinyl weighing 20 oz./lin. yd. (620 g/lin. m). Upgrade Vinyl shall meet or exceed CCC-W-408A-D and CFFA-W-101-B quality standards.
 3. Optional Upgrade Fabric: consisting of fade and tear resistant fabric that resists water-based stains weighing 13 oz./lin. yd. (403 g/lin. m).
 4. Optional Basics Carpet: consisting of acoustically absorbent, non-woven needle punch fibers fused to prevent fraying and unraveling of material weighing 28.5 oz./lin. yd. (884 g/lin. m). Basics Carpet shall achieve a minimum NRC rating of .65 in accordance with ASTM C 423.
 5. Optional Upgrade Carpet: consisting of acoustically absorbent, non-woven needle punch fibers fused to prevent fraying and unraveling of material weighing 23 oz./lin. yd. (713 g/lin. m). Upgrade Carpet shall achieve a minimum NRC rating of .60 in accordance with ASTM C 423.
 6. Optional Wood Veneer: consisting of unfinished flat cut wood veneer laminated to 1/2" [12.7] thick particle board core. Veneer shall be book / running matched within a panel, and vertically edge banded if Trimless astragals are specified.

(Notes: Optional Class "A" rated particle board is available. Acoustical substrate STC ratings apply for Wood Veneer panel construction.)

7. Optional Unfinished: consisting of panels with exposed acoustical substrate or steel skins for field applied wall covering or painting.
- B. Finish Material Supplier: Finish material shall be (select):
1. Standard Factory Supplied: from manufacturer's standard selection of finish materials, as specified.
 2. Optional Customer Supplied: from customer's selection of finish material, by others, and as approved by KWIK-WALL Company.

2.06 PERIMETER TRIM AND SEALS

- A. Vertical Trim and Seals: Panels shall have Trimless vertical astragals containing flexible vinyl seals and incorporate reversible tongue-and-groove-type configurations for positive interlocking with adjacent panels. Vertical trim shall not be permitted on the panel faces, resulting in a minimal groove appearance between adjacent panels.
- B. Horizontal Top Trim and Seals: Top seals shall consist of flexible vinyl sweep seals installed on both sides of the panel. The seals shall consist of a compressed bulb between two (2) fingers of vinyl. Top seal shall be fixed, providing continuous-contact flexible vinyl sealing against the bottom flange of the overhead track.
- C. Horizontal Bottom Trim and Seals: Bottom seals shall consist of multiple fingers of flexible vinyl for positive contact and sealing with various floor surfaces. Bottom seal type shall be (select):
1. Standard Automatic Bottom Seals: consisting of self activated seals providing 1½" [38] of nominal travel.
 2. Optional Adjustable Bottom Seals: consisting of field adjustable, continuous-contact vinyl sweep seals that allow for ¾" [19] of nominal adjustment.
 3. Optional Floating Bottom Seals: consisting of continuous-contact vinyl sweep seals that ride on an aluminum chassis containing two (2) omni-wheel rollers that are under constant spring pressure towards the floor surface. Floating Bottom Seals shall provide up to 3" [76] of nominal travel to accommodate uneven floor conditions.
- D. Horizontal and Vertical Panel Trim: All exposed panel trim and hinges shall be of one (1) similar color (select):
1. Dark Bronze.
 2. Grey. (Note: Not available for Floating Bottom Seals.)

2.07 CLOSURE SYSTEMS

- A. Initial Closure System: The lead panel (the first panel exiting the stack) shall form a seal vertically against a rigid wall surface. The initial closure shall be accomplished by an Adjustable-Compensating Closure containing two (2) continuous-contact, flexible vinyl bulb seals installed along the vertical edge of the lead panel for positive compression against a rigid wall surface. Initial closure panel shall contain a flush pull handle on each side.
- B. Final Closure System: The final closure panel (the last panel exiting the stack) shall form a seal vertically against a rigid wall surface. Final closure shall be accomplished by a Half Panel that does not require any attachment to the permanent wall. The Half Panel and its two (2) immediately adjacent panels will incorporate adjustable bottom seals, and the first panel adjacent to the half panel shall contain a flush pull handle. The type of final closure panel shall be (select):
1. Standard Manual Half Panel Pivot Closure: consisting of a Half Panel requiring manual activation when extending or retracting the operable wall.
(Note: Minimum of five (5) panels required for Manual Half Panel Pivot Closure system.)
 2. Optional Automatic Half Panel Pivot Closure: consisting of a Half Panel attached to a mechanical closure device with a 50 to 1 ratio worm gear and 1 H.P. (.746 kw) electric motor allowing the

operable wall to extend or retract automatically.

(Note: Minimum of eight (8) panels required for Automatic Half Panel Pivot Closure system.)

Note: Optional Automatic Bottom Seal is not available in conjunction with Final Closure panel(s).

2.08 ACOUSTICAL PERFORMANCE

- A. Certification: The operable wall shall have been tested in an independent acoustical testing laboratory in accordance with ASTM E 90 and ASTM E 413 test procedures.
- B. STC Rating: The operable wall acoustical performance rating shall be based on (select):
1. Standard Steel Skins: with a standard rating of 52 STC, or optional ratings of 46 STC, 50 STC or 55 STC.
(Note: Not available with optional Wood Veneer.)
 2. Optional Acoustical Substrate: with optional ratings of 43 STC, 46 STC, 48 STC or 50 STC.

2.09 PANEL ACCESSORIES

- A. Accessories including Single Pass Doors, Keyed Cylinder Locks, Concealed Door Closures, Room Viewers, Exit Signs, Dry Marker Writing Surfaces, Recessed Eraser Trays, Vision Lites, Tack Surfaces, and Pocket Doors shall be compatible with other accessories and options, furnished and installed by the operable wall manufacturer as noted on submitted shop drawings.

2.10 SAFETY DEVICES

- A. Optional safety devices by Guardian Personnel Protection System™. The following safety devices shall shut the operable wall off immediately and prevent any movement until the system is reset at the control box (select):
1. Lead Sensing Edge: consisting of a Lead Sensing Edge (approximately 5'-0" (1.52 m long)) located on lead edge of the operable wall. Lead Sensing Edge shall be wired to a wireless transmitter when activated an alarm will sound and shut the operable wall system off immediately.
 2. Floor Pressure Mats: consisting of molded vinyl mats (1/8" [3.18] thick) located in the pocket area and shall shut the operable wall system off immediately if a person or object is placed on mat. Floor mats shall only require 1 lb./ft.² (4.88 kg/m²) of pressure to activate.

(Note: Mat sizes may require additional width to pocket area.)

2.11 TRACK SYSTEM

- A. Type H.D. Continuously Hinged / Electric Steel Track: The Continuously Hinged / Electric Steel track running surface shall be made of cold-rolled, high carbon steel tread surfaces to facilitate ease of panel movement and operation. Track system shall not require a panel guide to straighten out the wall system.
- B. The steel tread surface shall be contained within a continuous structural track housing extruded from aluminum, which prohibits deterioration caused by rust or corrosion. The track housing shall have a durable anodized clear satin finish, which resists scratching, color fading and flaking. The track housing shall utilize grooves and interlocking steel pins for positive alignment of adjacent track sections, and shall be reinforced overhead by a heavy-duty steel bracket made of hot-rolled, 3/8" [10] thick plate steel. Aluminum track housing shall include an integral nut slot to accept a hardened steel square nut to facilitate attachment of each steel all-rod and splice brackets to the overhead structural support.

bearing steel wheels riding in a structural rectangular steel tube with $\frac{3}{8}$ " [10] diameter steel guide rails. Carrier shall utilize a constant-force spring allowing it to travel back and forth within the steel tube.

2.12 CARRIER SYSTEM

- A. Type H.D. Continuously Hinged / Electric Steel Wheel Carrier:
Each Continuously Hinged / Electric panel shall be top supported by one (1) carrier, utilizing a $\frac{5}{8}$ " [16] diameter pendant bolt. Each top carrier shall consist of four (4) permanently-lubricated, precision ball bearing polished steel wheels, as required for smooth and quiet operation. Floating bottom carrier shall consist of two (2) offset, permanently lubricated, precision ground ball

2.13 SUSPENSION SYSTEM

- A. Mounting System: The track shall be suspended by steel Drop Rods, consisting of adjustable rods of grade 2, $\frac{3}{8}$ " [10] diameter threaded steel all-rod provided with $\frac{3}{8}$ " [10] serrated steel nuts.

3.01 INSPECTION

- A. Proper and complete preparation of the operable wall system opening shall be by others in accordance with the architectural drawings, KWIK-WALL's shop drawings and ASTM E 557. Any deviation of the actual opening from these specifications shall be called to the attention of the architect prior to the installation of the operable wall.
- B. Deficiencies in the operable wall opening shall be corrected by others prior to installation of the operable wall.

3.02 INSTALLATION

- A. The operable wall system shall be installed by KWIK-WALL's authorized distributor.
- B. The operable wall shall be installed in accordance with KWIK-WALL's written instructions, shop drawings and ASTM E 557 installation guidelines.

MODEL 3050 PART 3 - EXECUTION

3.03 ADJUSTING AND CLEANING

- A. The operable wall panels and track system shall be adjusted and cleaned in accordance with KWIK-WALL's written instructions.

3.04 PROTECTION

- A. The operable wall panels shall be stored in the stacked (retracted) position prior to acceptance by the owner's representative.

3.05 DEMONSTRATION

- A. KWIK-WALL's authorized distributor shall demonstrate proper operation and explain proper and necessary maintenance requirements of the operable wall system to the owner's representative.

OPTIONS AND ACCESSORIES

KWIK-WALL offers a full complement of accessories for customizing any operable wall system to meet the specific needs of the most demanding project.

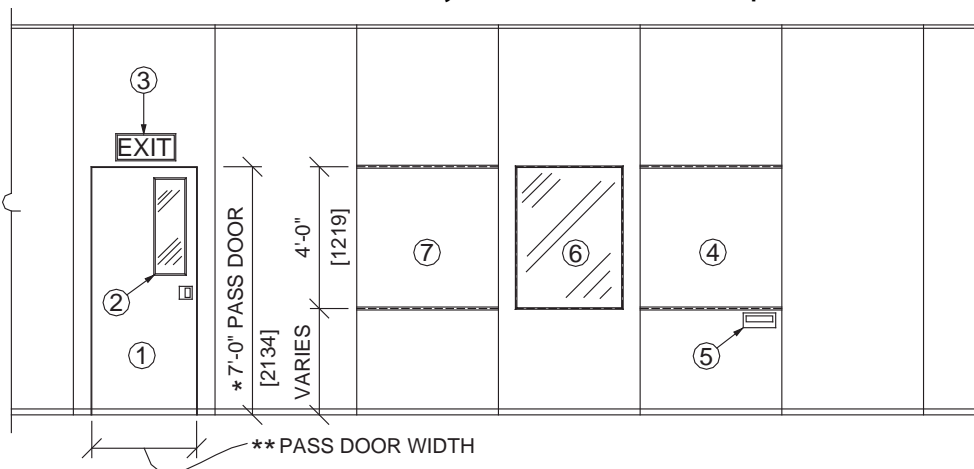

ACCESSORIES

1. Pass Door (Single shown, double available)
2. Pass Door Vision Lite
3. Exit Sign
4. Writing Surface
5. Recessed Eraser Tray
6. Panel Vision Lite
7. Tack Surface
8. Pocket Door (Not shown)

Notes:

1. * 8' - 6" [2.59] minimum panel fabrication height required.
2. ** Panel width minus 12" [305] equals pass door width.
3. For complete specifications and details of KWIK-WALL Accessories, please visit our website at www.kwik-wall.com.

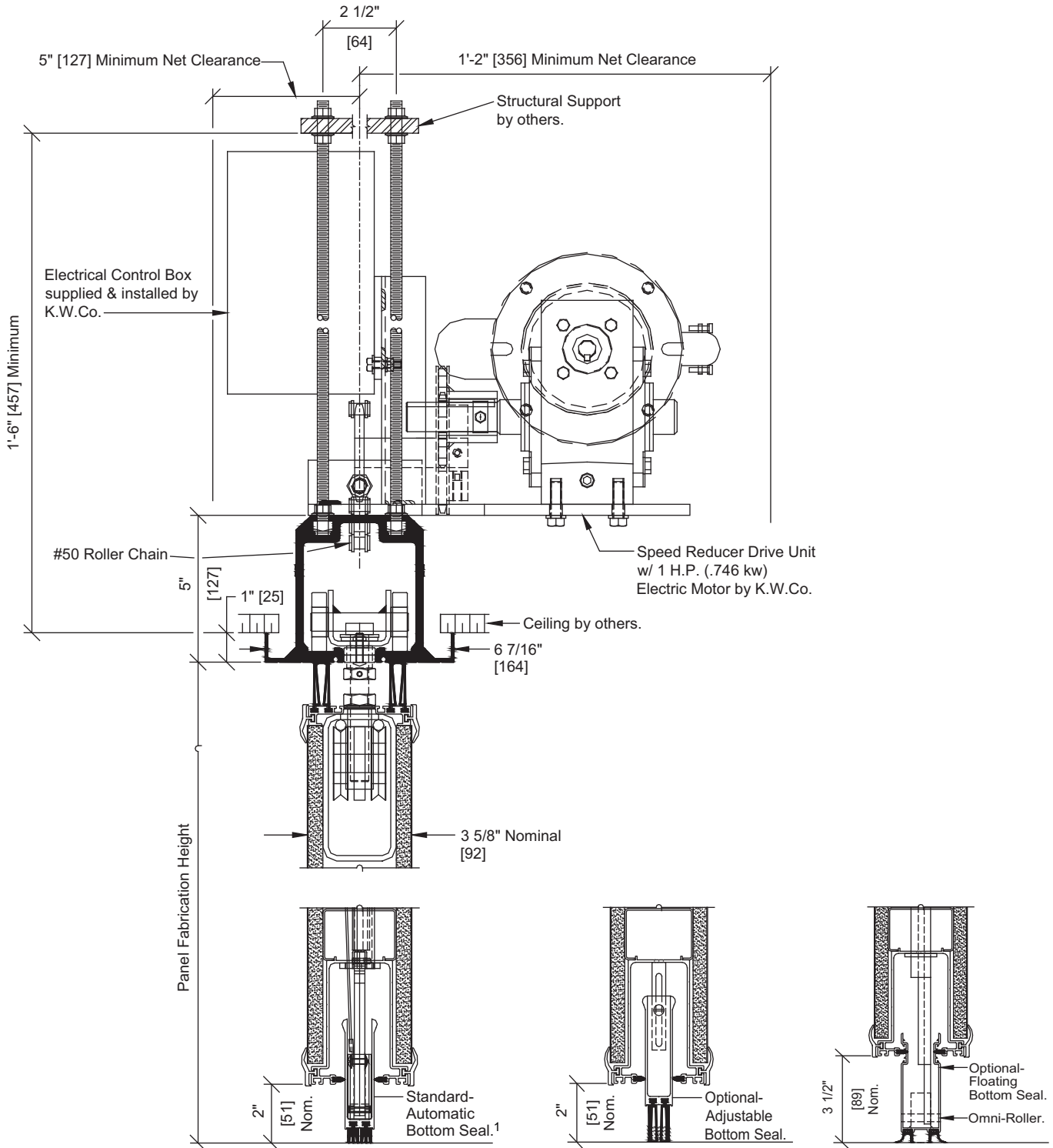

H.D. Continuously Hinged/Electric Steel Track and Carrier

Optional Adjustable Bottom Seal

Optional Floating Bottom Seal

Notes:

1. Adjustable Bottom Seals are standard on Final Closure Panel(s).
2. Maximum wall opening size shall not exceed 600ft.² (56m²)

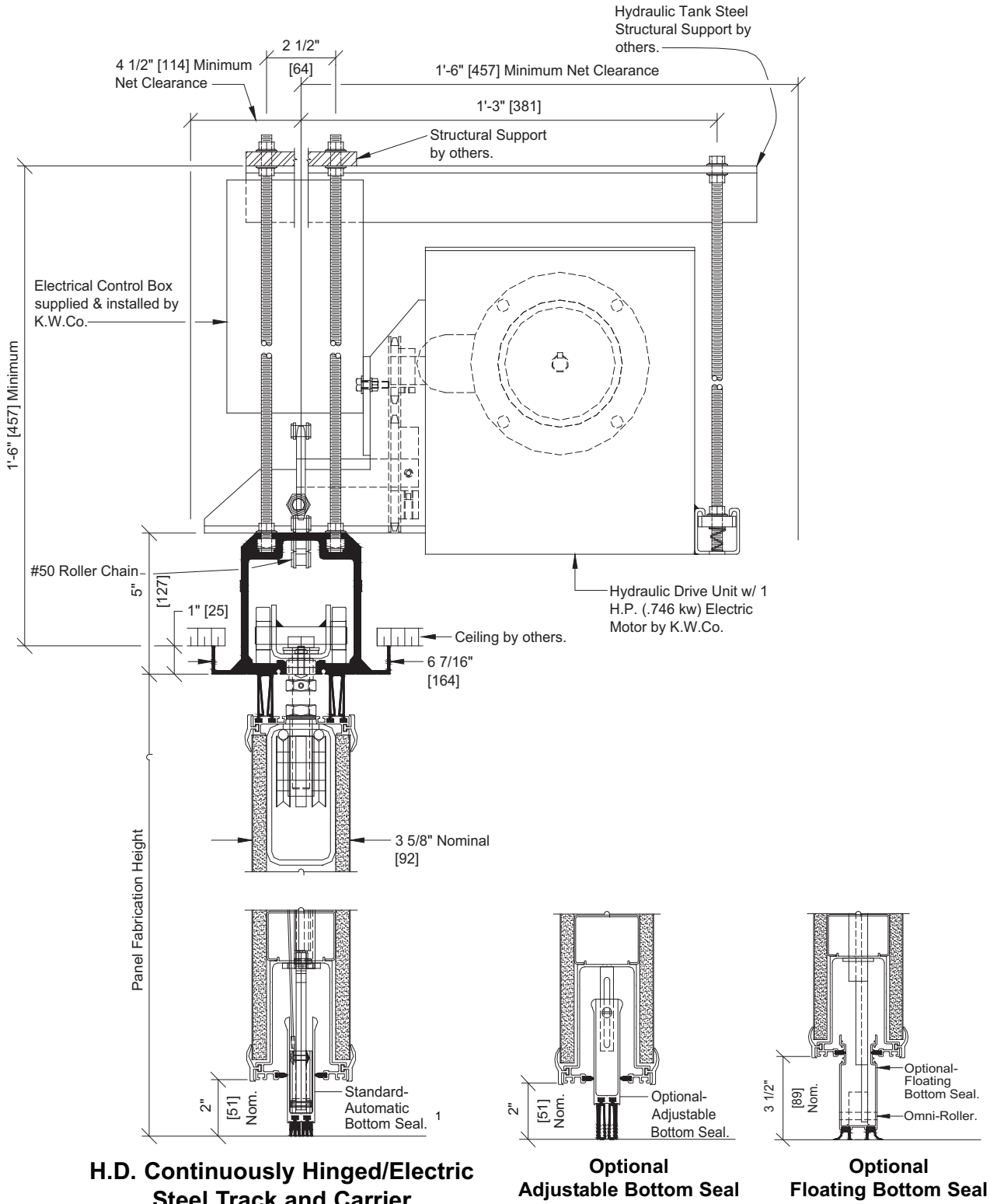

Notes:

1. Adjustable Bottom Seals are standard on Final Closure Panel(s).

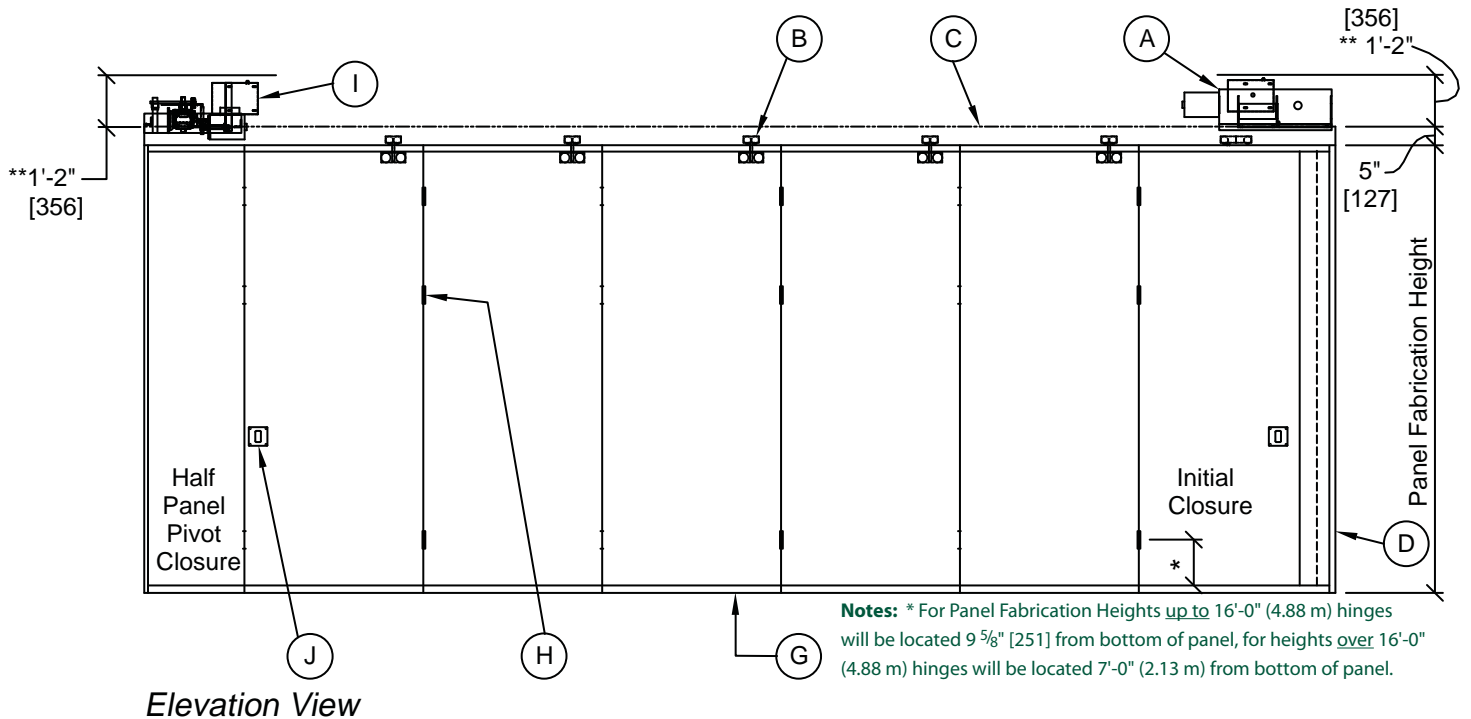
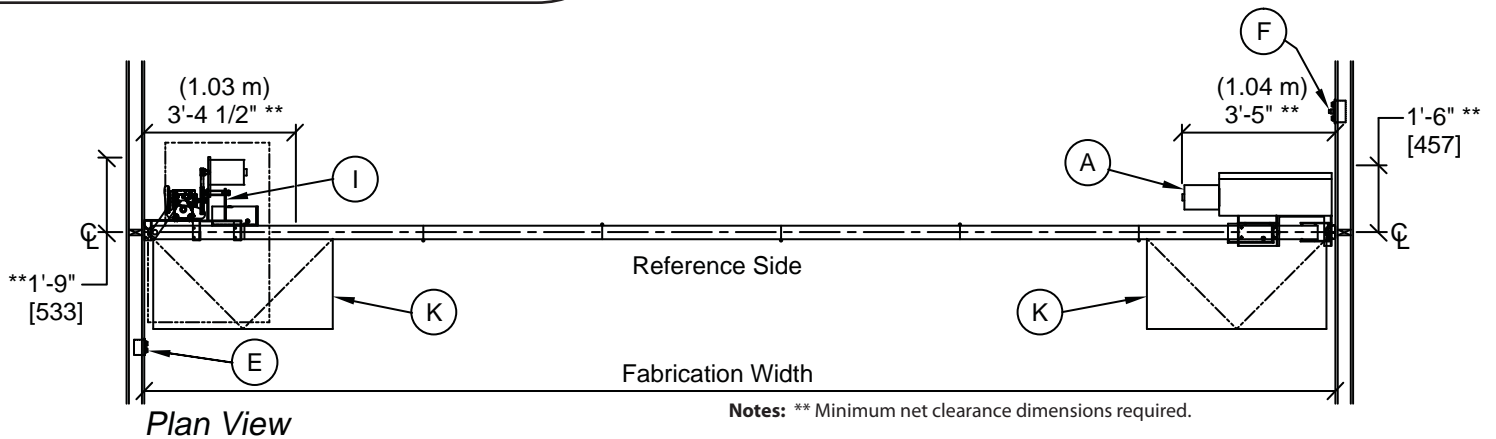

- A. Speed Reducer or Hydraulic Drive System
- B. Steel Floating Carrier Assembly
- C. H.D. Continuously Hinged / Electric Steel Track
- D. Adjustable-Compensating Closure
- E. Extend / Retract Constant-Pressure Push Button Switches
- F. Key Switch w/ Extend / Retract Constant-Pressure Push Button Switches
- G. Bottom Seals: Adjustable, Automatic or Floating
- H. Full Mortise Hinged
- I. Optional - Automatic Final Closure
- J. Flush Pull Handle
- K. Flush Mounted Access Panels by others (2'-0" [0.61m] x 4'-0" [1.22m] recommended)

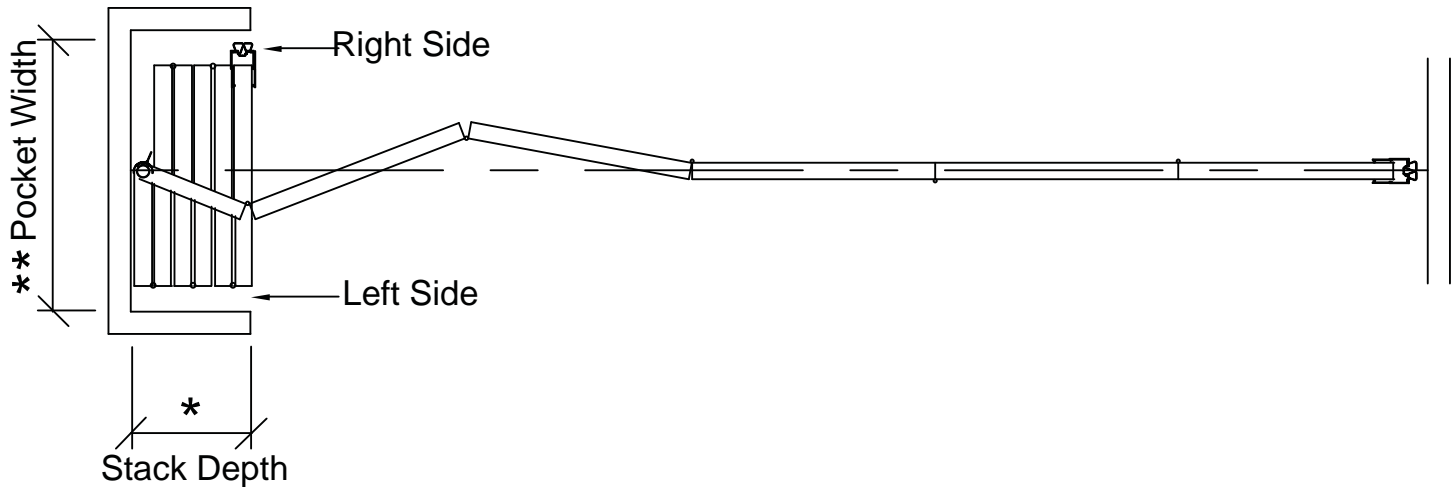

Standard Center Stack

Panels are conveniently stored at one (1) end and stacked "on-center" to the wall's installed position.

Stack Depth*

The depth of the stack area, as required for panel storage, is dictated by the total number of panels in the wall system. KWIK-WALL's Model 3050 - Steel Panels require 4⁵/₈" [117] per panel. To determine the stack depth, calculate as follows:

$$\text{Number of Panels} \times 4\frac{5}{8}'' [117] + 1'' [25]$$

*Note: Additional stack depth is required for wall systems containing the following type of panels:

- Pocket Door(s): 6" [152]

**Note: For wall systems that include Pocket Doors, please reference KWIK-WALL's "3000 Series Pocket Door" brochure for pocket layout dimensions and applications.

Pocket Width**

The width of the pocket is determined by the widest panel in the wall run. For specification purposes, assume the widest panel is 4'-0" (122 cm) maximum. Pocket width may be calculated as follows:

If Adjustable or Floating Bottom Seals are specified with:

Even number of panels = Panel Width + 4" [102] on Left Side and + 7" [178] on the Right Side.

Odd number of panels = Panel Width + 7" [178] on Left Side and + 4" [102] on Right Side.

If Automatic Bottom Seals are specified with:

Even number of panels = Panel Width + 4" [102] on the Left Side and + 1'-0 3/4" [324] on Right Side.

Odd number of panels = Panel Width + 1'-0 3/4" [324] on Left Side and + 4" [102] on Right Side.

Standard Half Panel Closure

For Continuously Hinged / Electric wall systems, final closure is accomplished by a half panel which pivots on an adjustable fulcrum plate attached to the finished floor. Designed specifically for Continuously Hinged walls, the Half Panel and its two (2) immediately adjacent panels will incorporate standard adjustable bottom seals.

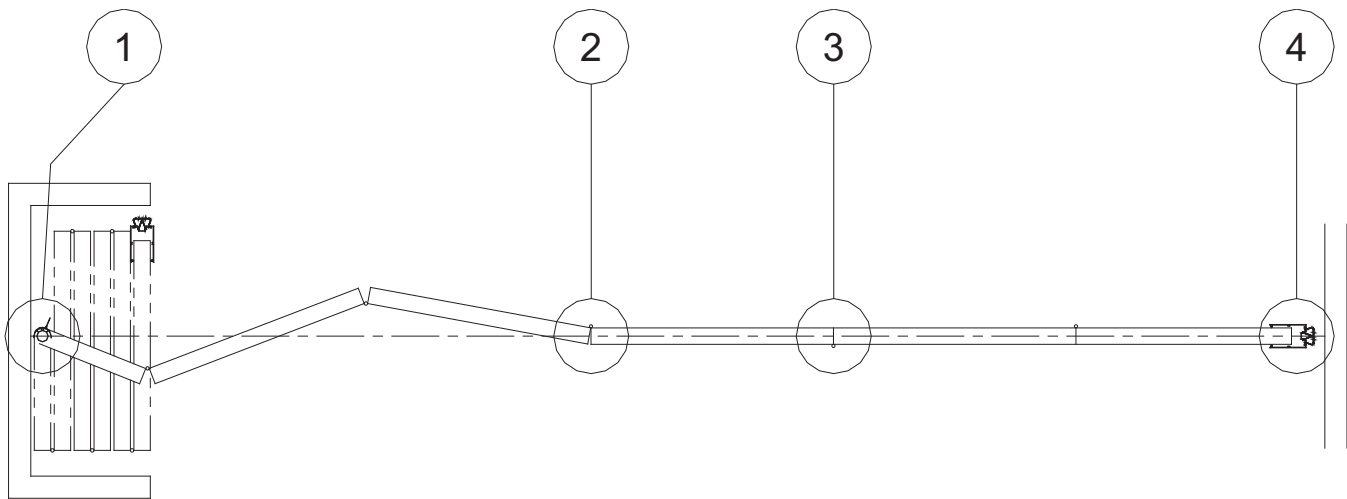

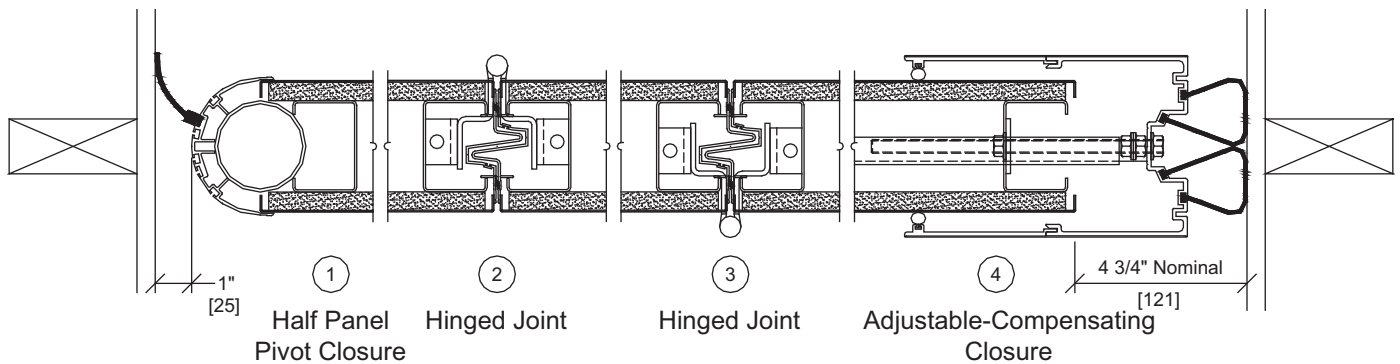

MODEL 3050 PRODUCT GUIDE
Standard Steel Skin Construction

STC Rating	Panel Thickness (nominal)	Max. Panel Weight lb./ft. ²	Maximum Panel Height	Maximum Wall Width*
46	3 ⁵ / ₈ " [92]	8.5 (41 kg/m ²)	24' - 2" [7.37]	99' - 9 3/8" [31.41]
50	3 ⁵ / ₈ " [92]	9.5 (46 kg/m ²)	24' - 2" [7.37]	99' - 9 3/8" [31.41]
52	3 ⁵ / ₈ " [92]	9.5 (46 kg/m ²)	24' - 2" [7.37]	99' - 9 3/8" [31.41]
55	3 ⁵ / ₈ " [92]	12.9 (63 kg/m ²)	24' - 2" [7.37]	99' - 9 3/8" [31.41]

* Maximum Wall Width dimension is for partitions that stack at one (1) end, if partition stacks at both ends maximum wall width = 150'-0" [45.72].

MODEL 3050 PRODUCT GUIDE
Optional Acoustical Substrate Construction

STC Rating	Panel Thickness (nominal)	Max. Panel Weight lb./ft. ²	Maximum Panel Height	Maximum Wall Width*
43	3 ⁵ / ₈ " [92]	5.9 (29 kg/m ²)	12' - 2" [3.71]	99' - 9 3/8" [31.41]
46	3 ⁵ / ₈ " [92]	6.6 (32 kg/m ²)	12' - 2" [3.71]	99' - 9 3/8" [31.41]
48	3 ⁵ / ₈ " [92]	7.5 (37 kg/m ²)	12' - 2" [3.71]	99' - 9 3/8" [31.71]
50	3 ⁵ / ₈ " [92]	9.0 (44 kg/m ²)	12' - 2" [3.71]	99' - 9 3/8" [31.71]

* Maximum Wall Width dimension is for partitions that stack at one (1) end, if partition stacks at both ends maximum wall width = 150'-0" [45.72].

*Optional Wood Veneer only available as Acoustical Substrate Construction.

MODEL 3050 OPERABLE WALL LIMITED WARRANTY

KWIK-WALL Company warrants each operable wall and its component parts to be free from defects in material and workmanship for a period of five (5) years from date of delivery to the original purchaser, when installed by an authorized KWIK-WALL distributor. KWIK-WALL Company reserves the right to have authorized personnel inspect any part alleged to be defective and to refuse any returned material unless the return was previously authorized by KWIK-WALL.

This warranty does not apply to any damage or deterioration caused by abuse or failure to provide reasonable and necessary maintenance. All field applied finishes, accessories or product modifications are specifically excluded under this warranty. KWIK-WALL's liability hereunder is limited to the replacement of any partition or component part found to be defective. Labor charges are the responsibility of the customer.

KWIK-WALL SHALL NOT BE LIABLE FOR ANY INCIDENTAL OR CONSEQUENTIAL DAMAGES. ALL OTHER WARRANTIES EXPRESSED OR IMPLIED INCLUDING ANY IMPLIED WARRANTY OF MERCHANTABILITY ARE HEREBY EXPRESSLY EXCLUDED.

Some states do not allow the exclusion or limitation of consequential or incidental damages, so the above limitation or exclusion may not apply to you.

This warranty gives you specific legal rights, and you may also have other rights which vary from state to state

Note:

Due to ongoing research and development, some variation may occur in product specifications and design. Please refer to your actual KWIK-WALL shop drawing(s) for exact product dimensions and specifications.

Distributed By:

