

KWIK-WALL... One Source for Wall Systems.

KWIK-WALL's 2000 Series - Steel Reinforced Panel operable wall systems answer the challenge for space division needs posed by multi-purpose room layouts. Years of continuing research and development have produced many outstanding features!

KWIK-WALL's 2040 Continuously Hinged / Manually operated system is especially suited for walls spanning 26'- 0" (7.92 m) or less. The panels are hinged together to form a continuous panel train, allowing for quick and easy manual setup. Simply pull on the lead panel and all the other panels follow in concert. The track system has been designed in a continuous straight run, which greatly simplifies the structural header requirements necessary for supporting the wall system.

SOUND CONTROL...

KWIK-WALL's 2000 Series - Steel Reinforced Panel is a complete line of acoustically rated wall systems that are designed and manufactured to meet the most demanding sound control requirements. Sound Transmission Class (STC) ratings from 42 STC to 51 STC have been tested and certified in an independent acoustical laboratory in accordance with ASTM E 90 and ASTM E 413 test procedures. The STC ratings represent a single number expression of the effectiveness of an operable wall in preventing the passage of transmitted sound in the range* of 125 Hz to 4,000 Hz. For assistance with designing room division applications using Operable, Glass or Accordion wall systems, please contact your local KWIK-WALL distributor.

*The average human ear has an audibility range from 125 Hz to 4,000 Hz. Levels in excess of 65 dB to 70 dB are generally too loud for ordinary speech communication. When the sound pressure exceeds 120 dB, it normally passes the threshold of pain.

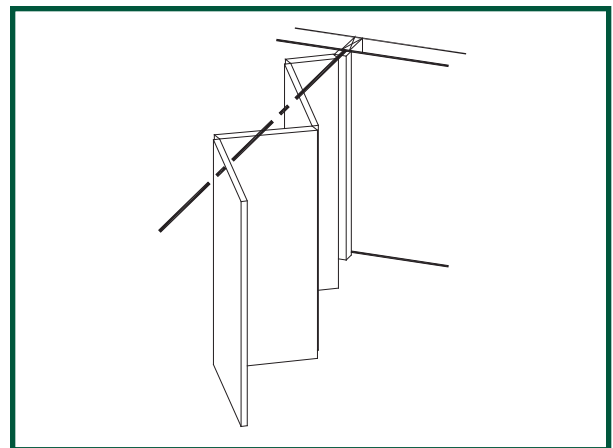

1.01 WORK INCLUDED

- A. Operable Wall System shall be furnished, installed and serviced by KWIK-WALL's authorized distributor, in compliance with the architectural drawings and specifications contained herein.

1.02 RELATED WORK

- A. Structural Support: Structural support system required for suspending the operable wall shall be designed, installed and pre-punched by others, in accordance with ASTM E 557 and KWIK-WALL's shop drawings.
- B. Insulation: Sound insulation and baffles for the plenum area above the track system, under the permanent floor, inside air ducts passing over or around the operable wall, and in permanent walls adjoining the operable wall system shall be by others, in accordance with ASTM E 557.
- C. Opening Preparation: Proper and complete preparation of the operable wall system opening shall be by others in accordance with ASTM E 557, and shall include floor leveling; plumbness of adjoining permanent walls; substrate and/or ceiling tile enclosures for the track system; and the painting and finishing of trim and other materials adjoining the head and jamb areas of the operable wall. Any permanent wall(s) receiving an adjustable hinged jamb will require internal structural blocking in order to secure the jamb to the permanent wall. Refer to a copy of the shop drawings for additional details.

1.03 SYSTEM DESCRIPTION

- A. The operable wall system shall consist of Continuously Hinged panels that are manually operated, featuring panels hinged together in a continuous panel train.
- B. The operable wall system shall consist of acoustically rated panels tested in accordance with ASTM E 90 and ASTM E 413 test procedures, and shall have achieved a STC rating as specified herein (see "Acoustical Performance" article listed under Part 2 - Products).

1.04 QUALITY ASSURANCE

- A. The operable wall shall have been tested in an independent acoustical testing laboratory in accordance with ASTM E 90 and ASTM E 413 test procedures.
- B. The operable wall panel construction and finish materials shall consist of Class A rated materials in accordance with ASTM E 84.
- C. The operable wall shall be installed by KWIK-WALL's authorized distributor in accordance with ASTM E 557.

1.05 REFERENCES

- A. ASTM E 90: Laboratory Measurement of Airborne-Sound Transmission Loss of Building Partitions.
- B. ASTM E 413: Determination of Sound Transmission Class (STC).
- C. ASTM E 557: Architectural Application and Installation of Operable Partitions.
- D. ASTM E 84: Surface Burning Characteristics of Building Materials.

- E. ASTM C 423: Standard Test Method for Sound Absorption and Sound Absorption Coefficients by the Reverberation Room Method.
- F. CCC-W-408A-D: Federal Specification which applies to Vinyl Coated Wall Coverings.
- G. CFFA-W-101-B: Chemical Fabrics and Film Association Quality Standard for Vinyl Coated Fabric Wall Coverings.

1.06 SUBMITTALS

- A. KWIK-WALL shall provide written technical information and related detail drawings, which demonstrate that the products comply with contract documents for each type of operable partition specified.
- B. KWIK-WALL shall provide detailed engineering drawings featuring track plan, panel elevation, horizontal and vertical details and beam punching template as required.
- C. KWIK-WALL shall provide written test report of the independent acoustical testing laboratory certifying the attainment of the specified STC rating, upon request.
- D. KWIK-WALL shall provide written instructions specifying the proper operation and maintenance of the operable wall system.
- E. KWIK-WALL shall provide a color selector demonstrating the manufacturer's selections of the specified finish material. Samples shall consist of actual swatches of the specified finish material.

1.07 DELIVERY, STORAGE AND HANDLING

- A. Panels shall be individually wrapped in a protective plastic covering to keep panels clean during delivery, storage and handling.
- B. Panels shall be stored on edge and above the floor on cushioned blocking in a dry and ventilated area, protected from humidity and temperature extremes.

1.08 SEQUENCING / SCHEDULING

- A. Beam Punching: KWIK-WALL shall provide beam punching template drawing detailing the anchor locations for the suspended track system (as required for Drop Rod Mounting), as required for the fabrication and installation of structural overhead support by others.
- B. Track Installation: Scheduling of operable wall track installation shall occur after structural overhead support has been properly and completely fabricated and installed by others.
- C. Panel Installation: Operable wall panel installation shall occur after fixed wall substrate construction is properly and completely installed by others, as required to protect panels from ongoing adjacent construction.

1.09 WARRANTY

- A. KWIK-WALL shall warrant each partition and its component parts to be free from defects in material and workmanship for a period of five (5) years from the date of delivery to the original purchaser, when installed by an authorized KWIK-WALL distributor (see actual warranty on Page 8 for details and limitations).

2.01 ACCEPTABLE MANUFACTURER

A. Operable walls shall be Series 2000, Model 2040 Continuously Hinged / Manual as manufactured by KWIK-WALL Company.

2.02 PANEL CONSTRUCTION

- A. Panel Dimensions: Standard panel dimension shall be a nominal 3" [76] thick.
- B. Panel Frame: Steel reinforced frame shall be constructed of structural aluminum alloy with steel corner supports. Panel frame shall be Class A rated in accordance with ASTM E 84.
- C. Panel Skins: Panel skins shall be Class A rated in accordance with ASTM E 84. Panel skin material shall consist of structural acoustical substrate pressure laminated to both sides of the steel reinforced frame to form a rigid, unitized and structural panel.
- D. Panel Hinges: Panel hinges shall be architectural grade, full leaf butt hinges.
- E. Panel Weight: Maximum panel weight shall be 6.5 - 11.0 lb./ft.² (32 - 54 kg/m²) depending on STC rating, size and options selected.

2.03 OPERATION

A. Operation shall be Continuously Hinged / Manual, consisting of panels hinged together forming a continuous panel train. Panels shall be top-supported by one (1) carrier in every pair.

2.04 STACK ARRANGEMENTS

- A. Stack Type: Panel storage configuration shall be Center Stack, consisting of panels stacked on center to the wall's installed position.
- B. Stack Quantity: Panels shall be stored at (select):
 1. Standard One End: on one end of the wall run.
 2. Optional Both Ends: on both ends of the wall run.

2.05 FINISHES

- A. Finish Material Type: Panel finish material shall be Class A rated in accordance with ASTM E 84, consisting of (select):
 1. Standard Vinyl: consisting of Type I, reinforced vinyl weighing 15 oz./lin. yd. (465 g/lin. m). Standard Vinyl shall meet or exceed CCC-W-408A-D and CFFA-W-101-B quality standards.
 2. Optional Upgrade Vinyl: consisting of Type II, reinforced vinyl weighing 20 oz./lin. yd. (620 g/lin. m). Upgrade Vinyl shall meet or exceed CCC-W-408A-D and CFFA-W-101-B quality standards.
 3. Optional Upgrade Fabric: consisting of fade and tear resistant fabric that resists water-based stains weighing 13 oz./lin. yd. (403 g/lin. m).
 4. Optional Basics Carpet: consisting of acoustically absorbent, non-woven needle punch fibers fused to prevent fraying and unraveling of material weighing 28.5 oz./lin. yd. (884 g/lin. m). Basics Carpet shall achieve a minimum NRC rating of .25 (applied over gypsum substrate) accordance with ASTM C 423.

5. Optional Upgrade Carpet: consisting of acoustically absorbent, non-woven needle punch fibers fused to prevent fraying and unraveling of material weighing 23 oz. / lin. yd. (713 g / lin. m). Upgrade Carpet shall achieve a minimum NRC rating of .20 (applied over gypsum substrate) in accordance with ASTM C 423.

6. Optional Wood Veneer: consisting of unfinished flat cut wood veneer laminated to 1/2" [12.7] thick particle board core. Veneer shall be book / running matched within a panel.

(Notes: Optional Class "A" rated particle board is available. Wood Veneer requires Cap-type astragal. Acoustical substrate STC ratings apply for Wood Veneer panel construction.)

- 7. Optional Unfinished: consisting of panels with exposed acoustical substrate for field applied wallcovering or painting.
- B. Finish Material Supplier: Finish material shall be (select):
 1. Standard Factory Supplied: from manufacturer's standard selection of finish materials, as specified.
 2. Optional Customer Supplied: from customer's selection of finish material, by others, and as approved by KWIK-WALL Company.
- C. Finish Material Application: Finish material shall be (select):
 1. Standard Factory Applied: by operable wall manufacturer. Customer supplied finish material samples must be submitted to manufacturer for testing and approval prior to acceptance and application.
 2. Optional Field Applied: by others.

2.06 PERIMETER TRIM AND SEALS

A. Vertical Trim and Seals: Panels shall have vertical astragals containing flexible vinyl seals and incorporate reversible tongue and-groove-type configurations for positive interlocking with adjacent panels. Vertical astragal type shall be (select):

MODEL 2040 PRODUCT GUIDE Standard Acoustical Substrate Construction				
STC Rating	Panel Thickness (nominal)	Max. Panel Weight lb./ft. ²	Maximum Panel Height	Maximum Wall Width
42	3" [76]	6.5 (32 kg/m ²)	12' - 2" (3.71 m)	26' - 0" (7.92 m)
45	3" [76]	8.5 (41 kg/m ²)	12' - 2" (3.71 m)	20' - 0" (6.10 m)
49	3" [76]	9.8 (48 kg/m ²)	12' - 2" (3.71 m)	17' - 0" (5.18 m)
50	3" [76]	11.0 (54 kg/m ²)	12' - 2" (3.71 m)	15' - 0" (4.57 m)

*Optional Wood Veneer only available as Acoustical Substrate Construction.

*For ease of use, KWIK-WALL recommends that Continuously Hinged/Manually Operated wall systems be limited to a maximum of 12'-2" (3.71 m) panel fabrication height and 26'-0" (7.92 m) total wall span stacked at one (1) end (depending on panel construction). If partition stacks at both ends take maximum wall width x 2. Please contact KWIK-WALL for requirements that exceed these limitations.

1. Standard Trimless Astragal: consisting of an aluminum extrusion with tongue-and-groove-type vertical astragals. Vertical trim shall not be permitted on the panel faces, resulting in a minimal groove appearance between adjacent panels.
 2. Optional Cap-type Astragal: consisting of an aluminum extrusion with tongue-and-groove-type vertical astragals for protecting the finish material and substrate along the vertical edge of the panel.
- B. Horizontal Top Trim and Seals: Top seals shall consist of flexible vinyl sweep seals installed on both sides of the panel. The seals shall consist of a compressed bulb between two (2) fingers of vinyl. Top seal shall be fixed, providing continuous contact flexible vinyl sealing against the bottom flange of the overhead track.
- C. Horizontal Bottom Trim and Seals: Bottom seals shall consist of multiple fingers of flexible vinyl for positive contact and sealing with various floor surfaces. Bottom seal type shall be (select):
1. Standard Automatic Bottom Seals: consisting of self activated seals providing 1½" [38] of nominal travel.
 2. Optional Adjustable Bottom Seals: consisting of field adjustable, continuous-contact vinyl sweep seals that allow for ¾" [19] of nominal adjustment.
 3. Optional Floating Bottom Seals: consisting of continuous contact, vinyl sweep seals that ride on an aluminum chassis containing two (2) omni-wheel rollers that are under constant spring pressure towards the floor surface. Floating Bottom Seals shall provide up to 3" [76] of nominal travel to accommodate uneven floor conditions.
- D. Horizontal and Vertical Panel Trim: All exposed panel trim and hinges shall be of one (1) similar color (select):
1. Dark Bronze.
 2. Grey. (Note: Not available for Floating Bottom Seals.)

2.07 CLOSURE SYSTEMS

- A. Initial Closure System: The lead panel (the first panel exiting the stack) shall form a seal vertically against a rigid wall surface. The initial closure shall be accomplished by a continuous-contact, flexible vinyl bulb seals installed along the vertical edge of the lead panel for positive compression against a rigid wall surface. Initial closure panel shall contain a flush pull handle on each side.
- B. Final Closure System: The final closure panel (the last panel exiting the stack) shall form a seal vertically against a rigid wall surface. The final closure shall be accomplished by a Half Panel, which is hinged permanently and directly to a structural wall. The Half Panel and its two (2) immediately adjacent panels shall incorporate adjustable bottom seals, and the first panel adjacent to the half panel shall contain a flush pull handle.

Note: Optional Automatic Bottom Seal is not available in conjunction with Final Closure panels.

2.08 ACOUSTICAL PERFORMANCE

- A. Certification: The operable wall shall have been tested in an independent acoustical testing laboratory in accordance with ASTM E 90 and ASTM E 413 test procedures.

- B. STC Rating: The operable wall acoustical performance rating shall be based on Standard Acoustical Substrate with a standard rating of 49 STC, or optional ratings of 42 STC, 45 STC or 50 STC.

2.09 PANEL ACCESSORIES

- A. Accessories including Pass Doors; Concealed Door Closures, Room Viewers, Exit Signs, Dry Marker Writing Surfaces, Recessed Eraser Trays, Vision Lites, Tack Surfaces and Pocket Doors shall be compatible with other accessories and options, furnished and installed by KWIK-WALL's authorized distributor as noted on submitted shop drawings.

2.10 TRACK & PANEL GUIDE SYSTEM

- A. Type 850 Continuously Hinged / Manual Aluminum Track: The operable wall track system shall be certified for up to 850 lb. (386 kg) of total live load weight per panel, and extruded from structural aluminum alloy, which prohibits deterioration caused by rust or corrosion. The aluminum track shall have a durable anodized clear satin finish, which resists color fading and flaking. The track shall utilize grooves and interlocking steel pins for positive alignment of adjacent track sections. The track joints shall be reinforced overhead by a heavy-duty steel bracket made of hot-rolled, ⅜" [10] thick plate steel. Aluminum track shall include an integral nut slot to accept a hardened steel square nut to facilitate attachment of each steel all-rod and splice brackets to the overhead structural support.
- B. Type 850 Aluminum Panel Guide: The panel guide shall be extruded from structural aluminum alloy, which prohibits deterioration caused by rust or corrosion. The aluminum panel guide shall have a durable anodized clear satin finish, which resists color fading and flaking. The panel guide shall utilize a groove and interlocking steel pins for positive alignment of adjacent panel guide sections. Panel guide shall be located on both sides of the exposed track surface to assist in straightening the continuously hinged train of panels. The exposed ends of the panel guide shall have a gathering nose to assist in straightening the operable wall panels and, to prevent damage to the panel faces.

2.11 CARRIER SYSTEM

- A. Type 850 Polymer Tire Carrier: Each pair of Continuously Hinged / Manual panels shall be top supported by one (1) carrier capable of supporting up to 850 lb. (386 kg) of total live load weight per panel, utilizing a ⅝" [16] diameter pendant bolt. Each carrier shall consist of eight (8) permanently lubricated, precision ball bearing steel wheels with high strength polymer tires, as required for smooth and quiet operation.

2.12 SUSPENSION SYSTEMS

- A. Mounting System: The track shall be supported by (select):
1. Standard Drop Rod Mount: consisting of adjustable rods of grade 2, ⅜" [10] diameter threaded steel all-rod provided with ⅜" [10] serrated steel nuts.
 2. Optional Drop Rod Bracket Mount: consisting of ⅜" [10] thick steel brackets mounted to top of track and supported with adjustable rods of grade 2, ⅜" [10] diameter threaded steel all-rod provided with ⅜" [10] serrated steel nuts.

3.01 INSPECTION

- A. Proper and complete preparation of the operable wall system opening shall be by others in accordance with the architectural drawings, manufacturers shop drawings and ASTM E 557. Any deviation of the actual opening from these specifications shall be called to the attention of the architect prior to the installation of the operable wall.
- B. Deficiencies in the operable wall opening shall be corrected by others prior to installation of the operable wall.

3.02 INSTALLATION

- A. The operable wall system shall be installed by KWIK-WALL's authorized distributor.
- B. The operable wall shall be installed in accordance with KWIK-WALL's written instructions, shop drawings and ASTM E 557 installation guidelines.

3.03 ADJUSTING AND CLEANING

- A. The operable wall panels and track system shall be adjusted and cleaned in accordance with KWIK-WALL's written instructions.

3.04 PROTECTION

- A. The operable wall panels shall be stored in the stacked (retracted) position prior to acceptance by the owner's representative.

3.05 DEMONSTRATION

- A. KWIK-WALL's authorized distributor shall demonstrate proper operation and explain proper and necessary maintenance requirements of the operable wall system to the owner's representative.

STACK ARRANGEMENT

Standard Center Stack

Panels are conveniently stored at one or both end(s) and stacked on-center to the wall's installed position.

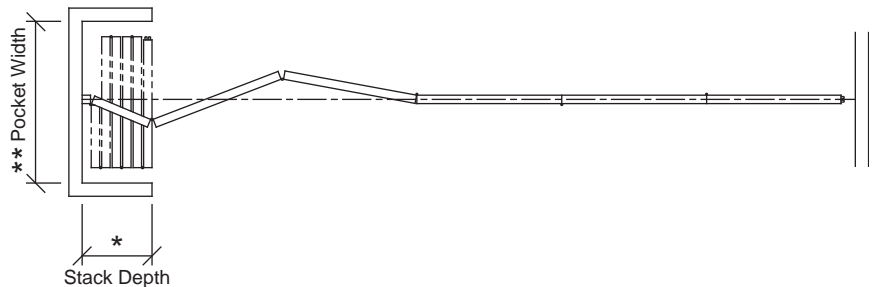

Stack Depth*

The overall depth of the stack area, as required for panel storage, is dictated by the total number of panels in the wall system. KWIK-WALL's Model 2040 - Steel Reinforced panels require 3³/₄" [95] per panel, plus 4" [102] for a hinged jamb. To determine the stack depth, calculate as follows:

$$\text{Number of Panels} \times 3\frac{3}{4}'' [95] + 4'' [102]$$

*Note: Additional stack depth is required for wall systems containing the following type of panels:

- Pocket Door(s): 6" [152]

**For wall systems that include Pocket Doors, please reference KWIK-WALL's "2000 Series Pocket Door" brochure for pocket layout dimensions and applications.

Pocket Width**

The width of the pocket is determined by the widest panel in the wall run. For specification purposes, assume that the widest panel is 4' - 0" (122 cm) maximum. Wall systems that utilize Automatic type bottom seals will require extra pocket width to allow clearance for the actuator that protrudes from the bottom of the lead panel. Pocket width may be calculated as follows:

If Adjustable or Floating Bottom Seals are specified

Widest Panel + 11" [279]
(allows 5¹/₂" [140] hand clearance on each side)

If Automatic Bottom Seals are specified:

Widest Panel + 10" [254]
(for actuator clearance on one side)

plus

5¹/₂" [140]
(for hand clearance on the other side)

KWIK-WALL offers a full complement of accessories for customizing any operable wall system to meet the specific needs of the most demanding project.

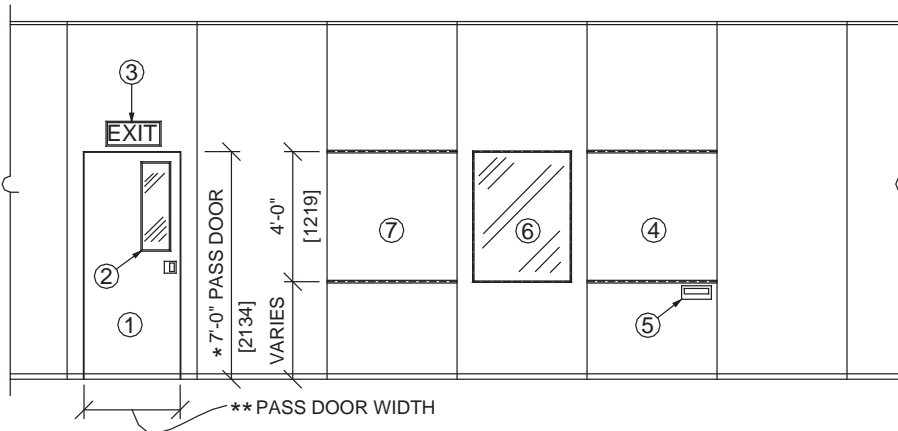

ACCESSORIES

1. Pass Door (Single shown, double available)
2. Pass Door Vision Lite
3. Exit Sign
4. Writing Surface
5. Recessed Eraser Tray
6. Panel Vision Lite
7. Tack Surface
8. Pocket Door (Not shown)

Notes:

1. * 8' - 6" (2.59 m) minimum panel fabrication height required.
2. ** Panel width minus 12" [305] equals pass door width.
3. For complete specifications and details of KWIK-WALL Accessories, please visit our website at www.kwik-wall.com.

VERTICAL DETAILS

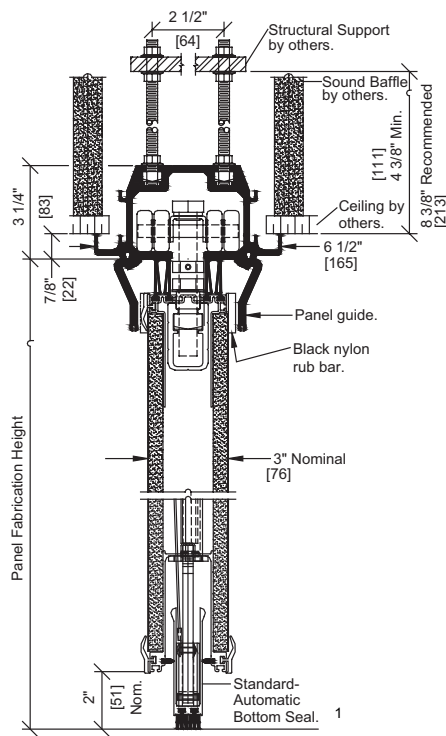

850 Continuously Hinged/Manual Aluminum Track and Carrier

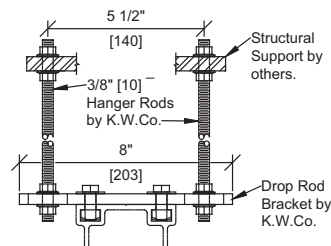

Optional Drop Rod Bracket Mount

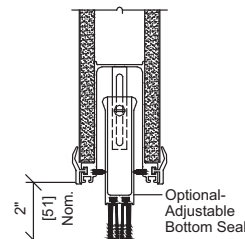

Optional Adjustable Bottom Seal

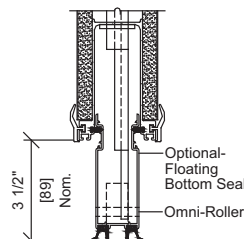

Optional Floating Bottom Seal

Notes:

1. Standard automatic bottom seal is not available with final closure panels.

Standard Half Panel Closure

For Continuously Hinged / Manual wall systems, final closure is accomplished by a half panel which is hinged permanently and directly to a structural wall. Designed specifically for Continuously Hinged walls, the half panel and its two (2) immediately adjacent panels will incorporate standard adjustable bottom seals or (optional) floating bottom seals. The first (full size) panel adjacent to the half panel will include a flush pull handle.

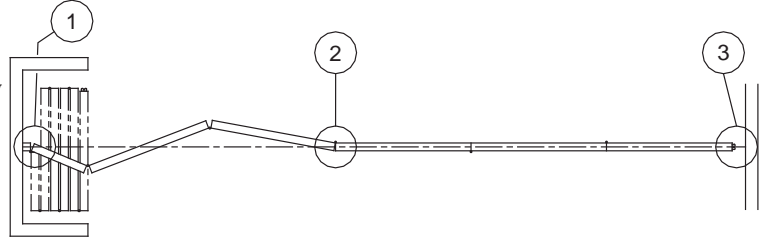

HORIZONTAL DETAILS

with TRIMLESS VERTICAL ASTRAGAL

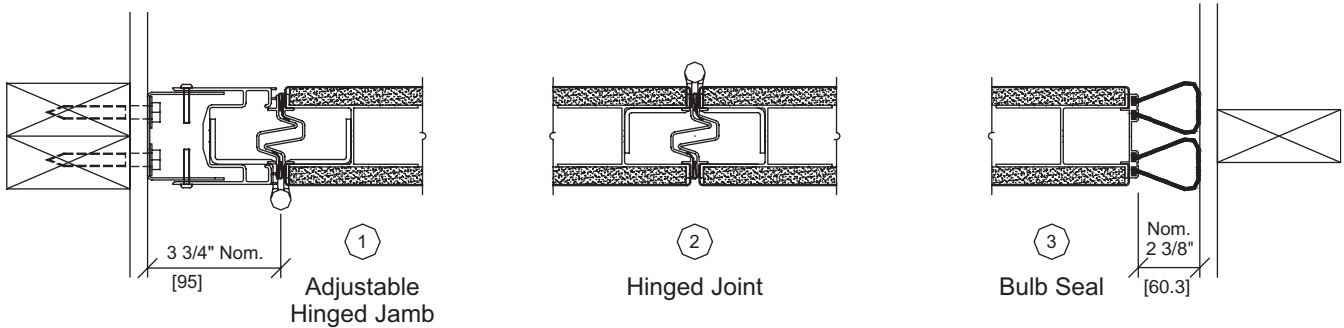

with CAP-TYPE VERTICAL ASTRAGAL

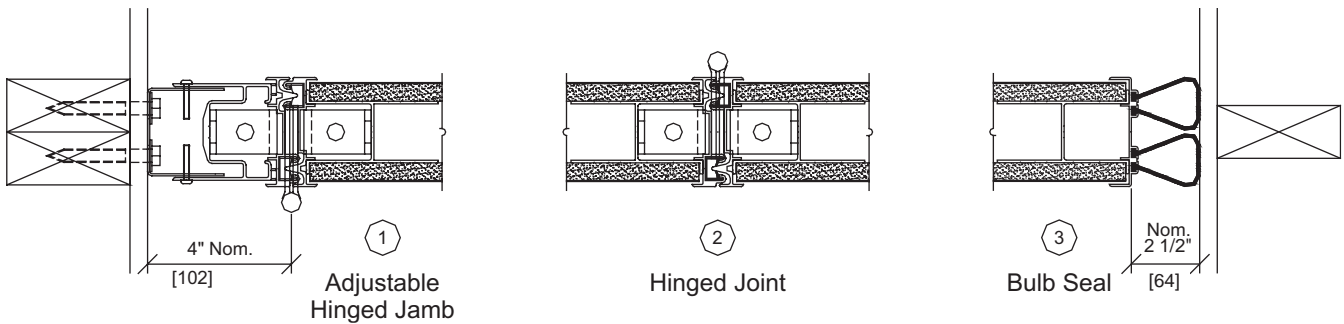

MODEL 2040 OPERABLE WALL LIMITED WARRANTY

KWIK-WALL Company warrants each operable wall and its component parts to be free from defects in material and workmanship for a period of five (5) years from date of delivery to the original purchaser, when installed by an authorized KWIK-WALL distributor. KWIK-WALL Company reserves the right to have authorized personnel inspect any part alleged to be defective and to refuse any returned material unless the return was previously authorized by KWIK-WALL.

This warranty does not apply to any damage or deterioration caused by abuse or failure to provide reasonable and necessary maintenance. All field applied finishes, accessories or product modifications are specifically excluded under this warranty. KWIK-WALL's liability hereunder is limited to the replacement of any partition or component part found to be defective. Labor charges are the responsibility of the customer.

KWIK-WALL SHALL NOT BE LIABLE FOR ANY INCIDENTAL OR CONSEQUENTIAL DAMAGES. ALL OTHER WARRANTIES EXPRESSED OR IMPLIED INCLUDING ANY IMPLIED WARRANTY OF MERCHANTABILITY ARE HEREBY EXPRESSLY EXCLUDED.

Some states do not allow the exclusion or limitation of consequential or incidental damages, so the above limitation or exclusion may not apply to you.

This warranty gives you specific legal rights, and you may also have other rights which vary from state to state.

Note:

Due to ongoing research and development, some variation may occur in product specifications and design. Please refer to your actual KWIK-WALL shop drawing(s) for exact product dimensions and specifications.

Distributed By:

