

### **KWIK-WALL... One Source for Wall Systems.**

KWIK-WALL's Variotec Series - Glass wall systems answer the challenge for space division needs.

This system ensures you can quickly and easily provide complete solutions for space division needs in hotels, schools, airports, shopping centers, sports arenas, residential layouts, and office buildings. Years of continuing research and development have produced many outstanding features.

KWIK-WALL's Variotec model offers an unmatched degree of flexibility via the modular track system that allows for virtually any layout or stacking arrangement including curving designs. The Variotec line is available with an elegant horizontal top and bottom glass retainer and trimless vertical edges, or a full perimeter. Trimmed frame for enhanced security and rigidity for all tall glass panels

### **FEATURES**

- Elegant top-fixed suspension and glass retainer
- One (1) standard and four (4) optional glass finish styles
- Virtually endless stacking arrangements
- Secure locking system

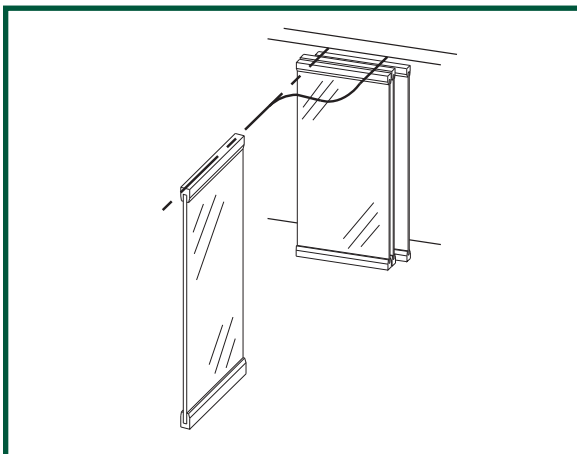

### 1.01 WORK INCLUDED

- A. Moveable glass wall system shall be furnished, installed, and serviced by a KWIK-WALL authorized distributor, in compliance with the architectural drawings and specifications contained herein.

### 1.02 RELATED WORK

- A. Structural Support: Structural support system required for suspending the moveable glass wall shall be designed, installed, and pre-punched by others, in accordance with ASTM E 557 and KWIK-WALL's shop drawings.
- B. Opening Preparation: Proper and complete preparation of the moveable glass wall system opening shall be by others in accordance with ASTM E 557, and shall include floor leveling; plumbness of adjoining permanent walls; substrate and / or ceiling tile enclosures for the track system; and the painting and finishing of trim and other materials adjoining the head and jamb areas of the moveable glass wall. Refer to a copy of the shop drawings for additional details.

### 1.03 SYSTEM DESCRIPTION

- A. The moveable glass wall system shall consist of Individual Panels that are top supported by two (2) carriers riding through radius Curve and Diverter type intersections.
- B. The moveable glass wall system shall consist of nominal  $\frac{3}{8}$ " [10] or  $\frac{1}{2}$ " [12.7] thick tempered glass panels suspended from a continuous aluminum glass retainer located at the top and bottom of each panel.

### 1.04 QUALITY ASSURANCE

- A. Installer Qualifications: An experienced installer who is certified in writing by KWIK-WALL as qualified to install KWIK-WALL's systems for work similar in material, design, and extent to that indicated for this project.
- B. The moveable glass wall panel shall utilize clear tempered glass per ASTM C 1048-04.
- C. The moveable glass wall shall be installed by a KWIK-WALL authorized distributor in accordance with ASTM E 557.

### 1.05 REFERENCES

- A. ASTM C 1036-01: Standard Specification for Flat Glass.
- B. ASTM C 1048-04: Standard Specification for Heat Treated Flat Glass.
- C. ASTM E 557: Architectural Application and Installation of Operable Partitions.

### 1.06 SUBMITTALS

- A. KWIK-WALL shall provide written technical information and related detail drawings, which demonstrate that products comply with contract documents for each type of moveable glass wall system specified.
- B. KWIK-WALL shall provide detailed engineering drawings featuring track plan, panel elevation, horizontal and vertical details and beam punching template as required.

### 1.07 DELIVERY, STORAGE AND HANDLING

- A. Panels shall be shipped in a completely enclosed wooden crate with high-density polystyrene blocks positioned between each panel to protect glass and hardware during delivery, storage and handling.
- B. Panels shall be stored on edge and above the floor on cushioned blocking in a dry and ventilated area, protected from humidity and temperature extremes.

### 1.08 SEQUENCING / SCHEDULING

- A. Beam Punching: KWIK-WALL shall provide beam punching template drawing detailing the anchor locations for the suspended track system for Drop Rod Mounting, as required for the fabrication and installation of structural overhead support by others.
- B. Track Installation: Scheduling of moveable glass wall track installation shall occur after structural overhead support has been properly and completely fabricated and installed by others.
- C. Panel Installation: Moveable glass wall panel installation shall occur after fixed wall substrate construction is properly and completely installed by others, as required to protect panels from ongoing adjacent construction.

### 1.09 WARRANTY

- A. KWIK-WALL shall warrant each moveable glass wall system and its hardware components to be free from defects in material and workmanship for a period of two (2) years from the date of delivery to the original purchaser, when installed by an authorized KWIK-WALL distributor. (Glass is specifically excluded from the warranty.)



## 2.01 ACCEPTABLE MANUFACTURER

- A. Moveable glass walls shall be CLEAR-DIVISIONS VARIOTEC TRIMLESS Individual Panels / Curve & Diverter as manufactured by KWIK-WALL Company.

## 2.02 PANEL CONSTRUCTION

- A. Panel Dimensions: Standard panel dimension shall be a nominal 1<sup>13/32"</sup> [36] thick.
- B. Horizontal Top and Bottom Rails: Top and bottom rails shall be continuous one-piece extrusion manufactured of structural grade aluminum as engineered by Hawa<sup>®</sup> with removable end caps. Rails shall utilize a cam lock feature to provide positive mechanical attachment to glass. (Passive friction type or adhesive applied rails shall not be allowed for safety reasons.)
- C. Bottom Rail Locking System: Each bottom rail glass retainer shall contain (select):
1. Standard Operable Floor Lock: consisting of a face activated lever located on one (1) side of the panel connected to a floor lock that engages a recessed spring loaded dust-proof strike to provide stability and security when the moveable glass wall system is setup in the extended position. Intermediate panels shall have horizontal interconnecting foot-operated lock or centering pin for additional stability and security.
  2. Optional Keyed / Thumb Turn Lock: consisting of key operated cylinders on both sides or key operation on one (1) side and thumb turn operation on opposite side.
  3. Optional Thumbturn: Consisting of an operable floor lock operated by a thumb turn that engages a recessed spring loaded dust-proof strike to provide stability and security when the moveable glass wall system is extended.
- D. Glass: Panels shall be glazed with 3/8" [10] or 1/2" [12.7] tempered glass that is manufactured in accordance with ASTM C 1036-01, ASTM C 1048-04, and ANSI Z 97.1. Glass finish shall be (select):
1. Standard Clear: consisting of clear tempered glass (select):
    - a. 3/8" [10] thick glass for Panel Heights up to 9'-0" (2.74 m).
    - b. 1/2" [12.7] thick glass for Panel Heights 12'-0" (3.65 m).
  2. Optional Smoked Bronze, Smoked Gray, Smoked Green, Smoked White or Clear Satin Etched: consisting of tinted laminated glass (select):
    - a. 3/8" [10] thick glass for Panel Heights up to 9'-0" (2.74 m).
    - b. 1/2" [12.7] thick glass for Panel Heights up to 12'-0" (3.65 m).
  3. Optional Clear Satin Etched: consisting of translucent tempered or laminated glass (select):
    - a. 3/8" [10] thick glass for Panel Heights up to 9'-0" (2.74 m).
    - b. 1/2" [12.7] thick glass for Panel Heights up to 12'-0" (3.65 m).
  4. Optional Decorated or Patterned: consisting of 3/8" [10] tempered glass decorated or patterned as selected by designer.

(Maximum Panel Height 9'-0" (2.74 m)).

5. Optional Berman editions: consisting of 3/8" [10] textured tempered glass with repeating pattern every 27" [685.8]. (Maximum Panel Height 11'-0" (3.35 m)). Texture shall be (select):
- a. esto: directional texture, multi-directional, random, horizontal forms across a lightly brushed background.
  - b. être: organic texture inspired by the natural markings found in granite.
  - c. ima: linear design with 1/8" [3.2] thick freehand lines every 1/2" [12.7] on a light être texture background.
  - d. aqui: organic texture with freehand vertical markings.
- E. Panel Weight: Maximum panel weight shall not exceed 330 lb. (150 kg) calculated at 7.35 lb. / ft.<sup>2</sup> (36 kg / m<sup>2</sup>). Sliding swing panel or sliding pivot panel shall not exceed 200 lb. (90.7 kg)

## 2.03 OPERATION

- A. Operation shall be Individual Panels / Curve & Diverter, consisting of Individual Panels that are top supported by two (2) carriers riding through radius Curve and Diverter type intersections.

## 2.04 STACK ARRANGEMENTS

- A. Stack Type: Panel storage configuration shall be (select):
1. Standard Perpendicular Stack: consisting of panels stacking at a 90° angle perpendicular to the wall's installed position.
  2. Optional Parallel Stack: consisting of panels stacking parallel to the wall's installed position.
  3. Optional Remote Stack: consisting of panels located remotely from the wall's installed position, as shown on the submitted shop drawings.
- B. Stack Quantity: Panels shall be stored in designated stack area as required for panel storage.

## 2.05 FINISHES

- A. Hardware Finish: Panel hardware including horizontal rails shall be finished of (select):
1. Standard Finish: Clear Anodized Aluminum.
  2. Optional Finish: Custom Anodized per supplied sample.
  3. Optional Finish: Powder Coated Paint to any RAL code.
- B. Pull Handle Finish: Handle finish shall be (select):
1. Standard Finish: consisting of Stainless Steel Satin Effect finish.
  2. Optional Finish: consisting of Pull Handle to match Hardware Finish selection (as close as possible).

## 2.06 PERIMETER TRIM AND SEALS

- A. Trim and Seals shall consist of (select):
1. Standard Trimless: consisting of 3/8" [10] or 1/2" [12.7] tempered glass with a sanded / beveled edge, resulting in a minimal groove appearance between adjacent glass panels.

2. Optional Vertical Protective Edge Trim: consisting of  $\frac{3}{8}$ " [10] or  $\frac{1}{2}$ " [12.7] tempered glass with a sanded / beveled edge utilizing a full vertical transparent protective edge trim encapsulating the edge of the glass.
3. Optional Vertical Protective Edge Trim with Brush Seal: consisting of  $\frac{3}{8}$ " [10] or  $\frac{1}{2}$ " [12.7] tempered glass with a sanded / beveled edge utilizing a full vertical transparent protective edge trim with light grey nylon brush seals to encapsulate the edge of the glass.
4. Optional Horizontal Top and Bottom Brush Seals: consisting of continuous contact black nylon brush seals provided on both sides of each panel.

## 2.07 CLOSURE SYSTEMS

- A. Initial Closure System: The lead panel (the first panel exiting the stack) shall intersect vertically against a rigid wall surface utilizing a face-activated foot lock with dust-proof strike recessed in floor, as accomplished by a lead panel that does not use any vertical jamb to affect initial closure. Trail edge of lead panel shall contain a foot-operated floor lock.
- B. Final Closure System: The final closure panel (the last panel at the stack end) shall provide a method for affecting final closure of the moveable glass wall system. The type of final closure panel shall be (select):
  1. Standard Fixed Pivot Panel Closure: consisting of a panel utilizing top and bottom pivots that allows the panel to pivot 90° in both directions and be used to affect final closure, and provides access thru the moveable glass wall system when it is setup in the extended position.

**Note:** Pivot Panel may not be required. Consult your KWIK-WALL representative for proper configuration. See page 7 for details.

2. Optional Fixed Swing Panel Closure: consisting of a panel utilizing top pivot and bottom pivot that engages with a self-closing unit containing a hold-open feature that is recessed flush into the floor allowing the panel to pivot 90° in both directions and be used to affect the final closure, and provides access thru the moveable glass wall system when it is setup in the extended position.
3. Optional Pocket Door(s): (see "Glass Wall Pocket Door" brochure for complete details and specifications).

## 2.08 PANEL ACCESSORIES

- A. Accessories including Sliding Pivot Panel, Sliding Swing Panel, and Floor Guide Channel shall be compatible with other accessories and options, furnished by KWIK-WALL as noted on submitted shop drawings.
  1. Sliding Pivot Panel: consisting of a panel that is moved into position and utilizes a top and bottom pivot that allows the panel to pivot 90° in both directions and be used to provide access thru the moveable glass wall system when it is setup in the extended position. Both sides of the panel shall contain a pull handle. (Refer to Part 2.05 "B. Pull Handle Finish").
  2. Sliding Pivot Panel with Surface Mounted Top Closure: consisting of a panel that is moved into position utilizing a top

and bottom pivot that allows the panel to pivot 90° and be used to provide access thru the moveable glass wall system when it is setup in the extended position. Top horizontal rail shall contain a surface mounted self-closing unit for the purpose of closing the panel when opened up. Both sides of the panel shall contain a pull handle. (Refer to Part 2.05 "B. Pull Handle Finish").

3. Sliding Swing Panel: consisting of a panel that is moved into position and utilizes a top pivot and bottom pivot that engages with a self-closing unit containing a hold-open feature that is recessed flush into the floor allowing the panel to swing 90° in both directions and be used to provide access thru the moveable glass wall system when it is setup in the extended position. Both sides of the panel shall contain a pull handle. (Refer to Part 2.05 "B. Pull Handle Finish").
4. Floor Guide Channel: consisting of a clear anodized extruded aluminum channel that is recessed into the floor (flush with finished floor) to provide additional stability to panels as they are moved in and out of their storage location.

## 2.09 TRACK SYSTEM

- A. Curve & Diverter Aluminum Track: The VARIOTEC track system shall be extruded of structural grade aluminum alloy, as engineered by Hawa®, and shall have a durable anodized clear satin finish, which resists color fading and flaking. Track shall utilize in line track splice connectors which provide positive track alignment of adjacent sections and shall be reinforced overhead by heavy-duty steel Drop Rod Brackets. Each Drop Rod Bracket shall have a pair of steel all-rods extending to the overhead structural support or direct mount.

## 2.10 INTERSECTIONS

- A. The "Curve" and "Diverter" intersections shall be fabricated from structural grade aluminum and fastened together to form a complete assembly.

## 2.11 CARRIER SYSTEMS

- A. Carrier: Each panel shall be top supported by two (2) carriers utilizing  $\frac{3}{8}$ " [10] (for panels weights up to 154 lb. (70 kg)) or  $\frac{9}{16}$ " [14] (for panel weights over 154 lb. (70 kg)) diameter pendant bolts. Each carrier shall contain permanently-lubricated, ball bearing steel wheels with high-density polymer tires as required for ease of panel movement.
- B. Carrier Size: The carrier size shall be (select):
  1. Type 154 Curve & Diverter Carrier: certified to be capable of supporting up to 154 lb. (70 kg) of total live load weight per panel.
  2. Type 220 Curve & Diverter Carrier: certified to be capable of supporting up to 220 lb. (100 kg) of total live load weight per panel.
  3. Type 330 Curve & Diverter Carrier: certified to be capable of supporting up to 330 lb. (150 kg) of total live load weight per panel.

**2.12 SUSPENSION SYSTEMS**

- A. Mounting Systems: The VARIOTEC track system shall be supported by (select):
1. Standard Drop Rod Bracket Mount: consisting of steel drop rod brackets with drop rods, consisting of adjustable rods of grade 2, 3/8" [10] diameter threaded steel all-rod provided with 3/8" [10] serrated steel nuts.
  2. Optional Direct Mount: consists of #16 x 3" [76] lag screws for attachment to a level overhead structural (wood) or steel support.

**3.01 INSPECTION**

- A. Proper and complete preparation of the moveable glass wall system opening shall be by others in accordance with the architectural drawings, KWIK-WALL's shop drawings and ASTM E 557. Any deviation of the actual opening from these specifications shall be called to the attention of the architect prior to the installation of the operable wall.
- B. Deficiencies in the moveable glass wall opening shall be corrected by others prior to installation of the moveable glass wall system.

**3.02 INSTALLATION**

- A. The moveable glass wall system shall be installed by KWIK-WALL's authorized distributor.
- B. The moveable glass wall shall be installed in accordance with KWIK-WALL's written instructions, shop drawings, and ASTM E 557 installation guidelines.

**3.03 ADJUSTING AND CLEANING**

- A. The moveable glass wall panels and track system shall be adjusted and cleaned in accordance with KWIK-WALL's written instructions.

**3.04 PROTECTION**

- A. The moveable glass wall panels shall be stored in the stacked (retracted) position prior to acceptance by the owner's representative.

**3.05 DEMONSTRATION**

- A. KWIK-WALL's authorized distributor shall demonstrate proper operation and explain proper and necessary maintenance requirements of the moveable glass wall system to the owner's representative.

<b>VARIOTEC PRODUCT SELECTION GUIDE</b>							
Model	Operation	Stack Arrangements	Glass	Perimeter Trim and Seals	Final Closure Options	Maximum Panel Height	Maximum Wall Width
Variotec Trimless	Individual Panels	Standard: Perpendicular Optional: Parallel or Remote Stack	Standard: Clear Optional: Smoked, Etched, Decorated or Patterned	Standard: Trimless Optional: Protective Edge	**Standard: Fixed Pivot Panel Optional: Fixed Swing Panel or Sliding Pivot panel	*12' - 0" (3.66 m)	Unlimited

\*Maximum panel height for Sliding Swing and Sliding Pivot Panel = 10'-0" (3.05 m) with a maximum panel weight of 200 lb. (90.7 kg). \*Maximum panel height for Berman editions glass = 11'-0" (3.35 m).

\*\*Pivot Panel may not be required. Consult your KWIK-WALL representative for proper configuration.

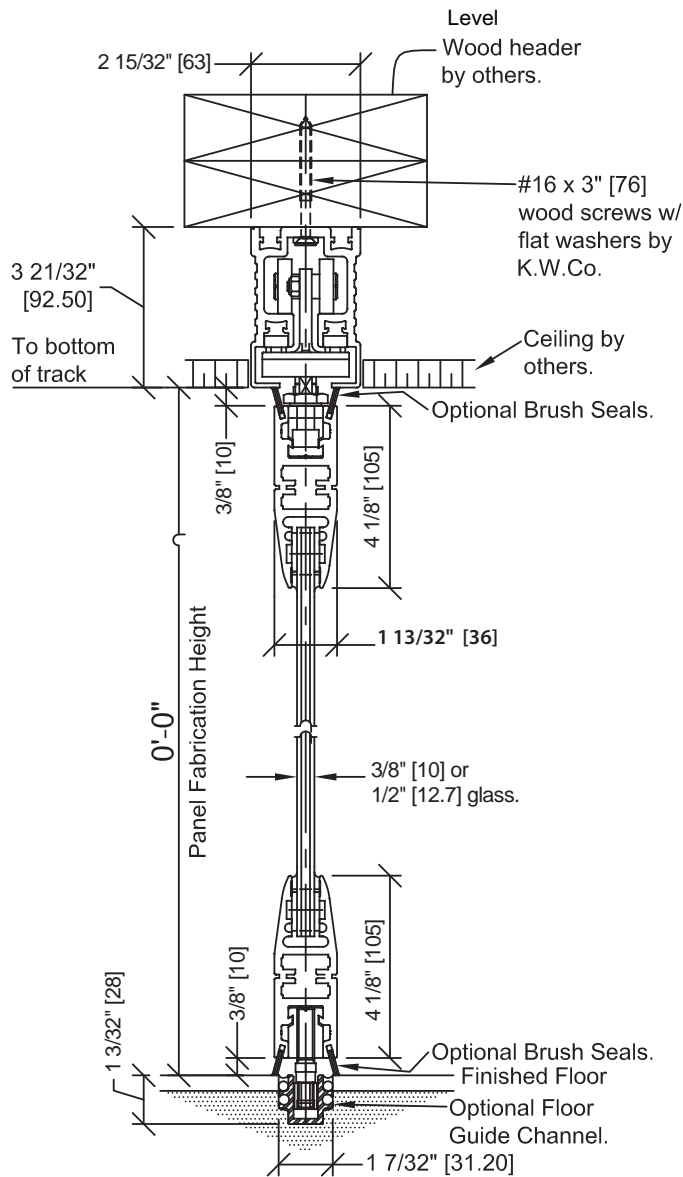

**Direct Mount with Floor Guide Channel  
and Brush Seals  
Variotec Trimless**

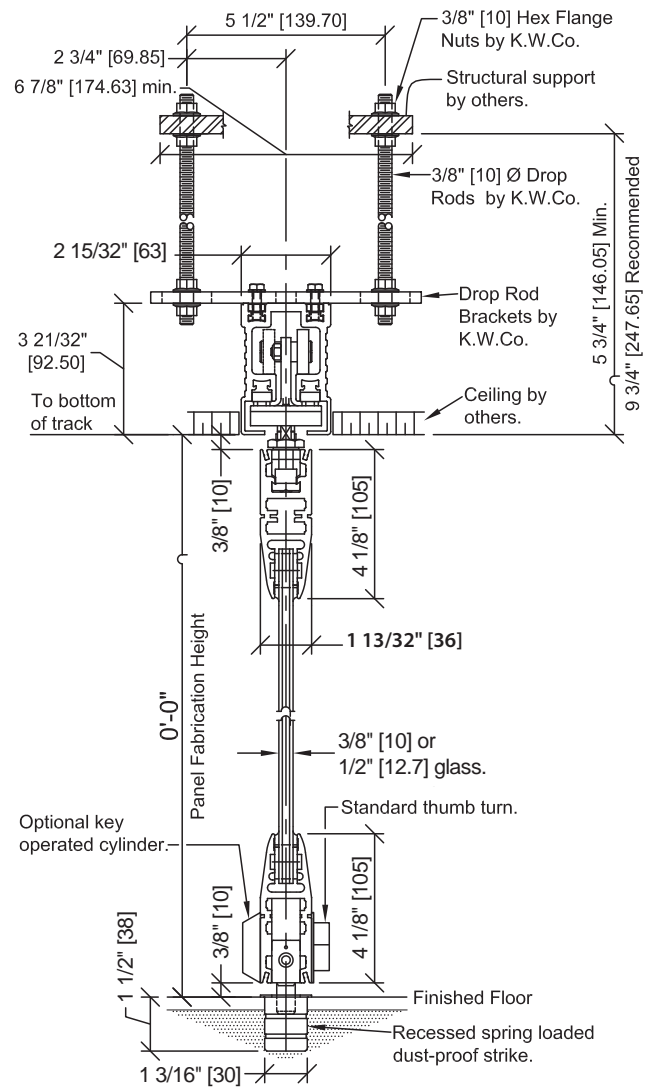

**Drop Rod Bracket Mount  
Variotec Trimless**

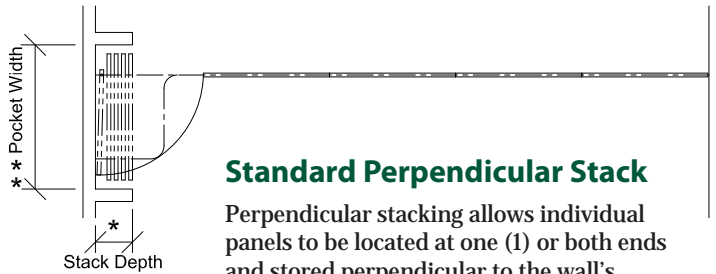

**Standard Perpendicular Stack**

Perpendicular stacking allows individual panels to be located at one (1) or both ends and stored perpendicular to the wall's installed position.

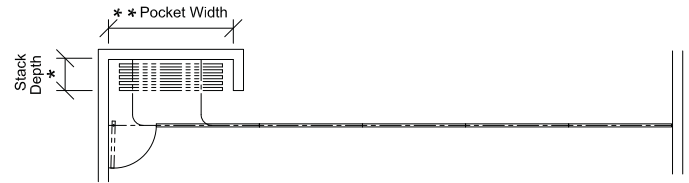

**Optional Parallel Stack**

In contrast to perpendicular stacking, Individual Panel arrangements may also be stored parallel to the wall's installed position, at one (1) or both ends.

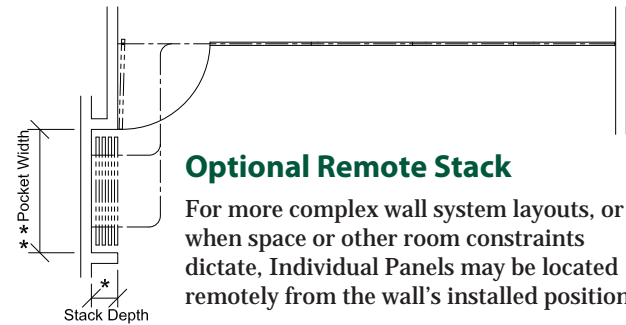

**Optional Remote Stack**

For more complex wall system layouts, or when space or other room constraints dictate, Individual Panels may be located remotely from the wall's installed position.

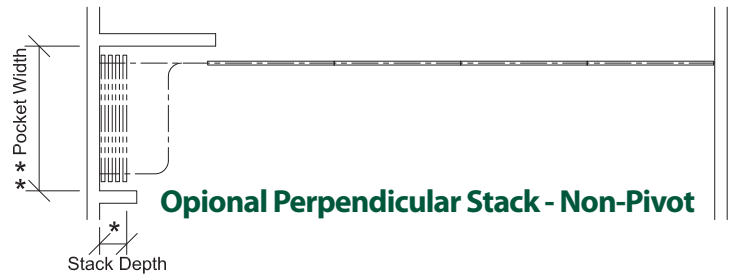

**Optional Perpendicular Stack - Non-Pivot**



**Optional Parallel Stack - Non-Pivot**

**Stack Depth\***

The overall depth of the stack area, as required for panel storage, is dictated by the total number of panels in the wall system. KWIK-WALL's Variotec panels require an average stack depth of 2<sup>3</sup>/<sub>4</sub>" [70] per panel. To determine the stack depth, calculate as follows:

**Number of Panels x 2<sup>3</sup>/<sub>4</sub>" [70] + 3<sup>1</sup>/<sub>4</sub>" [18]**

\*Note: Additional stack depth is required for wall systems containing the following type of panels:

- Handle: 3<sup>1</sup>/<sub>2</sub>" [89]
- Pivot Panel(s) Closure: 2<sup>3</sup>/<sub>8</sub>" [60]
- Pocket Door(s): 6" [152]

\*\*For wall systems that include Pocket Doors, please reference KWIK-WALL's "Variotec" brochure for pocket layout dimensions and applications.

**Pocket Width\*\***

The width of the pocket is determined by the widest panel in the wall run. For specification purposes, assume the widest panel is 4'-0" (122 cm) maximum. Pocket width may be calculated as follows:

**Panel Width + 7" [178]**  
(allows 3<sup>1</sup>/<sub>2</sub>" [89] for hand clearance on each side)

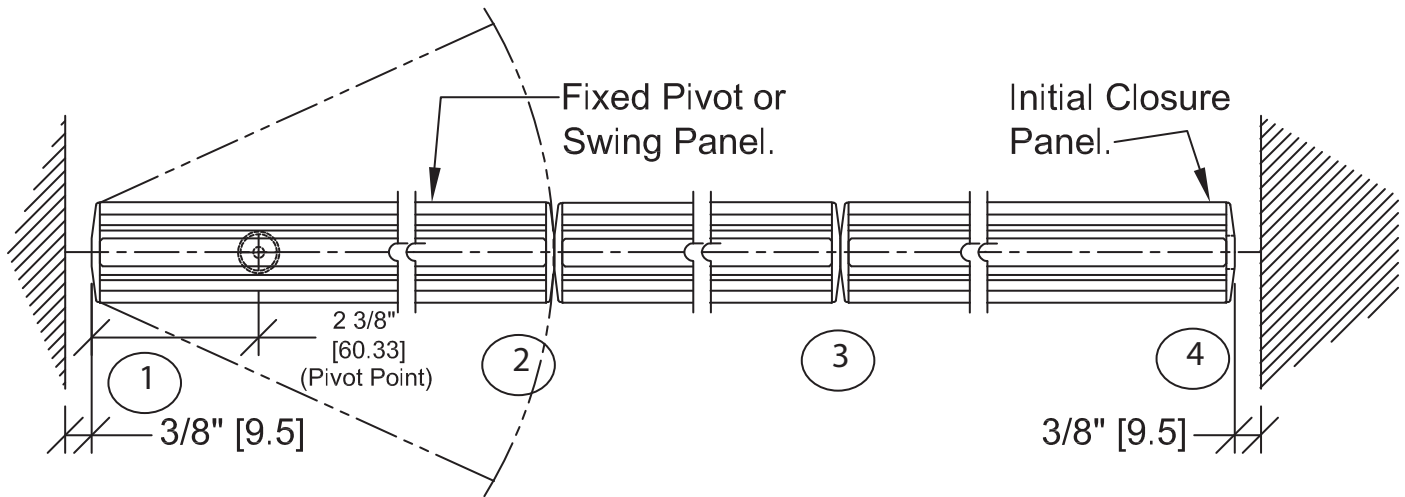

Horizontal Detail - Variotec Trimless

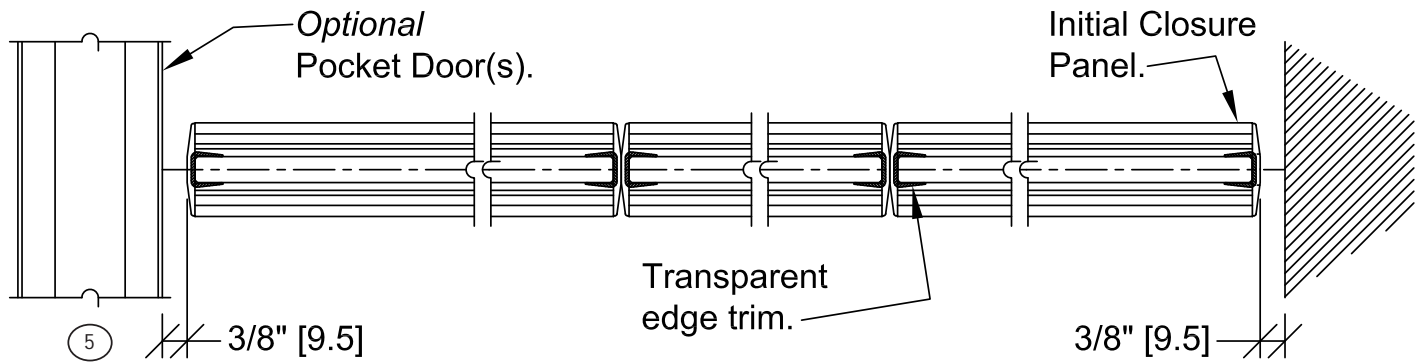

Horizontal Detail - Variotec w/  
Transparent Edge Trim

### Standard Fixed Pivot Panel

Consisting of a panel utilizing top and bottom pivots that allows the panel to pivot 90° in both directions. Provides access thru the wall system when setup is in extended position.

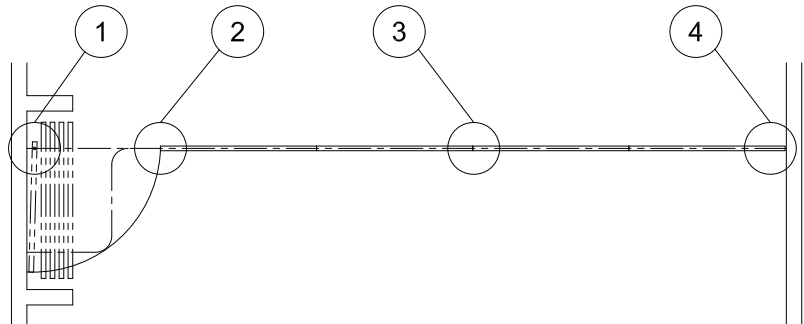

### Optional Fixed Swing Panel

Consisting of a panel utilizing top and bottom pivots that engages with a self-closing unit containing a hold open feature allowing the panel to pivot 90° in both directions. Provides access thru the wall system when setup is in extended position.

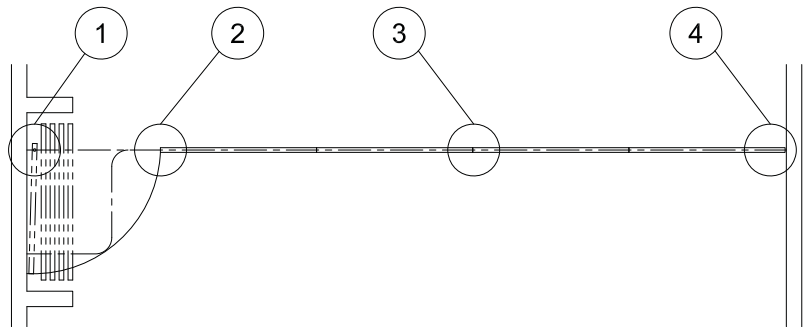

### Optional Single Sliding Pocket Door

Consisting of a single panel suspended by two (2) carriers traveling in an overhead track system. Bottom of panel shall contain a Door Guide attached to the floor to stabilize the panel. Panel shall contain a flush pull handle on both sides.

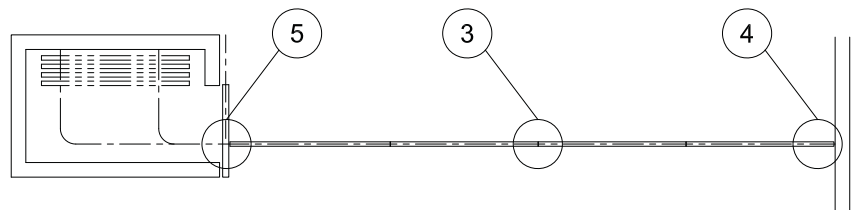

1. Pivot Door/Swing Door
2. Pivot meets Sliding Door
3. Typical Joint
4. Initial Closure Panel
5. Pocket Door

Horizontal details for numbers 1 through 5 can be found on page 8

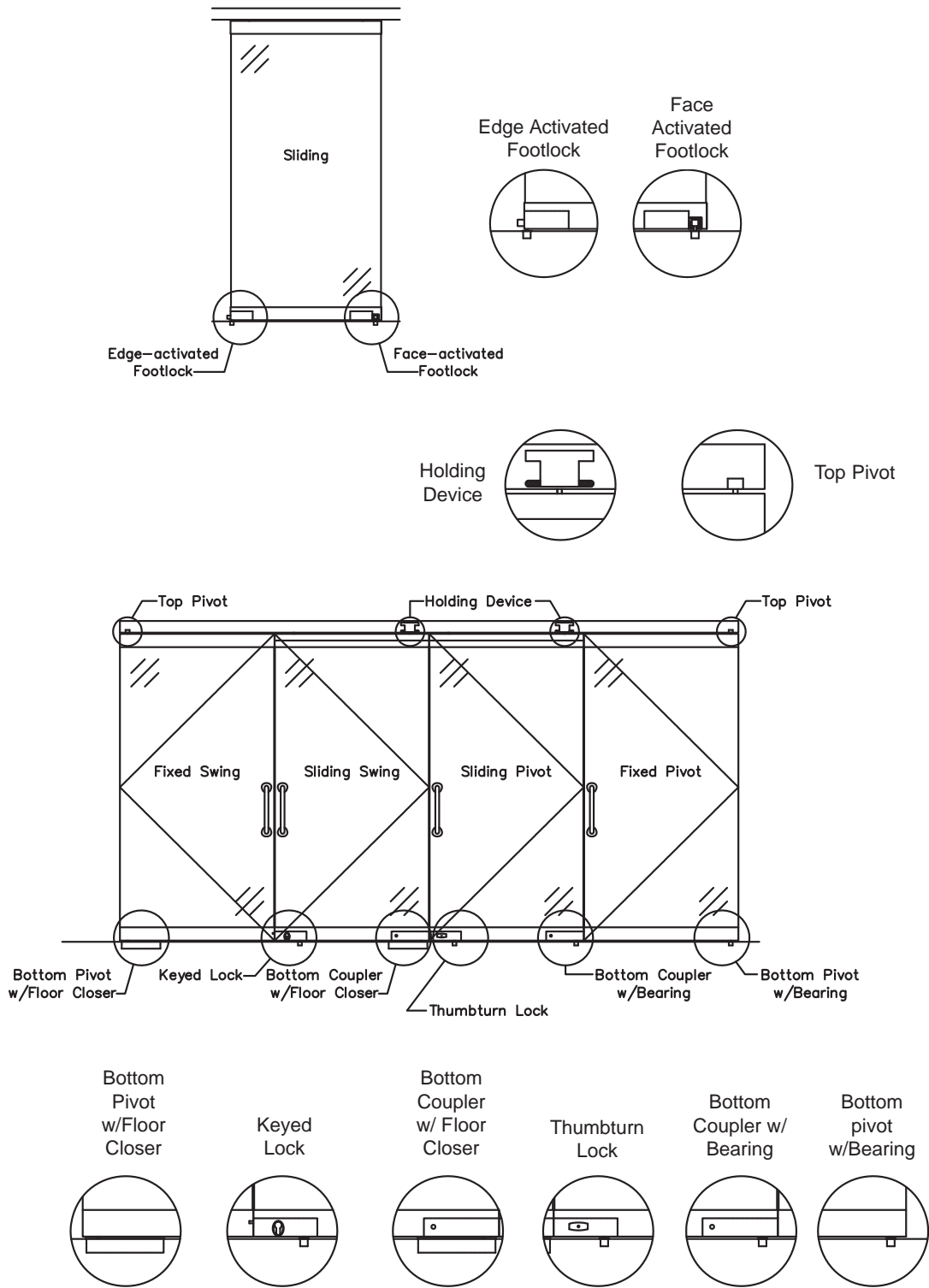

KWIK-WALL Offers a full complement of accessories for customizing any glass wall system to meet the specific needs of the most demanding project.

If you don't see the style or options and accessories you are looking for, KWIK-WALL has many other styles of Operable Glass Walls to bring you the solution to your space division needs.

The Product Selection Guide will step you through the various features of each model. Product stack arrangements and details show the more common elements for each model.

Model	APPLICATIONS		PRODUCT FEATURES						
	Interior	Exterior	Pivot Door	Sliding Pivot Panel	Sliding Swing Panel	Color Options	Trimmed Vertical Edge	Trimless Vertical Edge	Lock Options
Variotec	✓		✓	✓	✓	✓	✓	✓	✓
Cornertec	✓		✓			✓		✓	✓
Variofold	✓		✓			✓		✓	✓
Centerfold	✓		✓			✓		✓	✓
Aperto	✓		✓			✓		✓	✓
KWV-Tec	✓		✓			✓	✓	✓	✓
KWP-Fold	✓		✓			✓		✓	✓

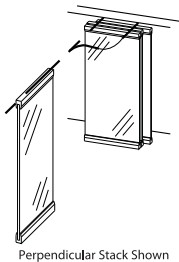

### Individual Panels - Perpendicular, Parallel, Remote or Custom Stack (Aperto, Variotec, Cornertec & KWV-Tec)

Individual Panels are top supported by two (2) carriers that operate in the track system that allows panels to move and turn effortlessly through radius intersections that are engineered for heavy glass panels. The versatility of stack arrangements includes Perpendicular Stack, Parallel Stack, Remote or Custom Stack.

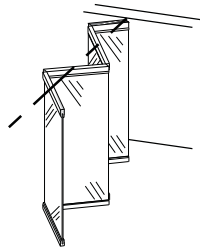

### Continuously Hinged Center Stack (Centerfold)

Continuously Hinged Panels are hinged together to form a continuous panel train that allows for easy set-up. The Center Stack arrangement provides panel storage at one or both ends of the wall's installed position. The final closure panel is a half panel.

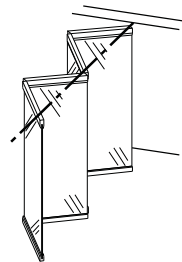

### Continuously Hinged - Offset Stack (Variofold)

Continuously Hinged Panels are hinged together to form a continuous panel train that allows for easy set-up. The Offset Stack System allows panels to be stacked perpendicular to the main track & offset to the right or left.

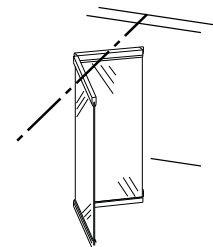

### Hinged Pairs Center Stack (KWP-Fold)

Hinged Pairs Panels are panels hinged together in groups of two (2), unless otherwise specified. Panels are top-supported by one (1) carrier in each panel. The Center Stack arrangement provides panel storage at one or both ends of the wall's installed position.

# VARIOTEC - TRIMLESS GLASS WALL LIMITED WARRANTY

KWIK-WALL Company warrants each glass wall and its component parts to be free from defects in material and workmanship for a period of two (2) years from date of delivery to the original purchaser, when installed by an authorized KWIK-WALL distributor. KWIK-WALL Company reserves the right to have authorized personnel inspect any part alleged to be defective and to refuse any returned material unless the return was previously authorized by KWIK-WALL. (Glass is specifically excluded from the warranty.)

This warranty does not apply to any damage or deterioration caused by abuse or failure to provide reasonable and necessary maintenance. All field applied finishes, accessories or product modifications are specifically excluded under this warranty. KWIK-WALL's liability hereunder is limited to the replacement of any partition or component part found to be defective. Labor charges are the responsibility of the customer.

***KWIK-WALL SHALL NOT BE LIABLE FOR ANY INCIDENTAL OR CONSEQUENTIAL DAMAGES. ALL OTHER WARRANTIES EXPRESSED OR IMPLIED INCLUDING ANY IMPLIED WARRANTY OF MERCHANTABILITY ARE HEREBY EXPRESSLY EXCLUDED.***

Some states do not allow the exclusion or limitation of consequential or incidental damages, so the above limitation or exclusion may not apply to you.

This warranty gives you specific legal rights, and you may also have other rights which vary from state to state

**Note:**

Due to ongoing research and development, some variation may occur in product specifications and design. Please refer to your actual KWIK-WALL shop drawing(s) for exact product dimensions and specifications.

***Distributed By:***

