

KWIK-WALL... One Source for Wall Systems.

KWIK-WALL's Variofold Series - Glass wall systems answer the challenge for space division needs in hotels, schools, airports, shopping centers, sports arenas, residential layouts, and office buildings. Years of continuing research and development have produced many outstanding features!

KWIK-WALL's Variofold model is a high-quality hardware system for all-glass folding-wall installations with an even number of panels, for partitioning rooms up to 17'-8½" (5.4 m) wide, (or 35'-5" (10.8 m) when stacked on both sides) as individually and transparently as required. The hardware stacks up to six door panels; a pivoted access door may also be installed on the opposite side to the folding stack.

FEATURES

- Completely concealed working parts
- One (1) standard and four (4) optional glass finish styles
- Offset Stacking
- May be equipped with a separate pivot or swing door
- Minimal space requirement in stacking area

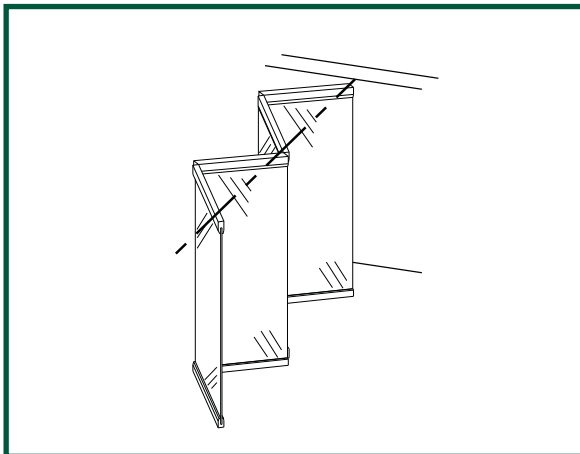

1.01 WORK INCLUDED

- A. Moveable glass wall system shall be furnished, installed, and serviced by a KWIK-WALL authorized distributor, in compliance with the architectural drawings and specifications contained herein.

1.02 RELATED WORK

- A. Structural Support: Structural support system required for suspending the moveable glass wall shall be designed, installed, and pre-punched by others, in accordance with ASTM E 557 and manufacturer's shop drawings.
- B. Opening Preparation: Proper and complete preparation of the moveable glass wall system opening shall be by others in accordance with ASTM E 557, and shall include floor leveling; plumbness of adjoining permanent walls; substrate and / or ceiling tile enclosures for the track system; and the painting and finishing of trim and other materials adjoining the head and jamb areas of the moveable glass wall. Refer to a copy of the shop drawings for additional details.

1.03 SYSTEM DESCRIPTION

- A. The moveable glass wall system shall consist of Continuously Hinged Panels that are manually operated, and top supported by one (1) carrier in every other panel with a bottom guide pin traveling in a recessed floor guide channel (flush with finished floor) providing lateral stability to the glass wall panels.
- B. The moveable glass wall system shall consist of nominal $\frac{3}{8}$ " [10] thick tempered glass panels suspended from a continuous aluminum glass retainer located at the top and bottom of each panel.

1.04 QUALITY ASSURANCE

- A. Installer Qualifications: An experienced installer who is certified in writing by KWIK-WALL as qualified to install KWIK-WALL's systems for work similar in material, design, and extent to that indicated for this project.
- B. The moveable glass wall panel shall utilize clear tempered glass per ASTM C 1048-04.
- C. The moveable glass wall shall be installed by a KWIK-WALL authorized distributor in accordance with ASTM E 557.

1.05 REFERENCES

- A. ASTM C 1036-01: Standard Specification for Flat Glass.
- B. ASTM C 1048-04: Standard Specification for Heat Treated Flat Glass.
- C. ASTM E 557: Architectural Application and Installation of Operable Partitions.

1.06 SUBMITTALS

- A. KWIK-WALL shall provide written technical information and related detail drawings, which demonstrate that products comply with contract documents for each type of moveable glass wall system specified.
- B. KWIK-WALL shall provide detailed engineering drawings featuring track plan, panel elevation, horizontal and vertical details and beam punching template as required.

1.07 DELIVERY, STORAGE AND HANDLING

- A. Panels shall be shipped in a completely enclosed wooden crate with high-density polystyrene blocks positioned between each panel to protect glass and hardware during delivery, storage and handling.
- B. Panels shall be stored on edge and above the floor on cushioned blocking in a dry and ventilated area, protected from humidity and temperature extremes.

1.08 SEQUENCING / SCHEDULING

- A. Beam Punching: Manufacturer shall provide beam punching template drawing detailing the anchor locations for the suspended track system for Drop Rod Mounting, as required for the fabrication and installation of structural overhead support by others.
- B. Track Installation: Scheduling of moveable glass wall track installation shall occur after structural overhead support has been properly and completely fabricated and installed by others.
- C. Panel Installation: Moveable glass wall panel installation shall occur after fixed wall substrate construction is properly and completely installed by others, as required to protect panels from ongoing adjacent construction.

1.09 WARRANTY

- A. KWIK-WALL shall warrant each moveable glass wall system and its hardware components to be free from defects in material and workmanship for a period of two (2) years from the date of delivery to the original purchaser, when installed by an authorized KWIK-WALL distributor. (Glass is specifically excluded from the warranty.)

2.01 ACCEPTABLE MANUFACTURER

- A. Moveable glass walls shall be CLEAR-DIVISIONS VARIOFOLD Continuously Hinged Panels as manufactured by KWIK-WALL Company.

2.02 PANEL CONSTRUCTION

- A. Panel Dimensions: Standard panel dimension shall be a nominal 1^{13/32"} [36] thick.
- B. Horizontal Top and Bottom Rails: Top and bottom rails shall be continuous one-piece extrusion manufactured of structural grade aluminum as engineered by Hawa[®]. Rails shall utilize a camlock feature to provide positive mechanical attachment to glass. (Passive friction type or adhesive applied rails shall not be allowed for safety reasons.) Horizontal top rail on each panel that does not contain a carrier shall include a stopper to prevent the glass wall panels from over-closing.
- C. Bottom Rail Locking System: Alternating bottom glass retainers shall contain (select):
1. Standard Operable Floor Lock: consisting of thumb turn located on one (1) side of the panel connected to a floor lock that engages a recessed spring loaded dust-proof strike (for openings of two (2) panels or less) or a floor guide channel (for openings greater than two (2) panels) to provide security when the moveable glass wall system is extended.
 2. Optional Keyed / Thumb Turn Lock: consisting of key operated cylinders on both sides or key operation on one (1) side and thumb turn operation on opposite side.
- D. Glass: Panels shall be glazed with 3/8" [10] tempered glass that is manufactured in accordance with ASTM C 1036-01, ASTM C 1048-04 and ANSI Z97.1. Glass finish shall be (select):
1. Standard Clear: consisting of 3/8" [10] clear tempered glass.
 2. Optional Clear Satin Etched: consisting of 3/8" [10] translucent tempered glass.
 3. Optional Decorated or Patterned: consisting of 3/8" [10] tempered glass decorated or patterned as selected by Designer.
 4. Optional Berman editions: consisting of 3/8" [10] textured tempered glass with repeating pattern every 27" [685.8]. Texture shall be (select):
 - a. esto: directional texture, multi-directional, random, horizontal forms across a lightly brushed background.
 - b. être: organic texture inspired by the natural markings found in granite.
 - c. ima: linear design with 1/8" [3.2] thick freehand lines every 1/2" [12.7] on a light être texture Background.
 - d. aquí: organic texture with freehand vertical markings.
- E. Panel Weight: Maximum panel weight shall not exceed 176 lb. (80 kg) calculated at 7.35 lb. / ft.² (36 ft² / m²).
- F. Hinges: Panel hinges shall be architectural grade, full leaf butt type, with a Dull Chrome finish.

2.03 OPERATION

- A. Operation shall be Continuously Hinged Panels that are top supported by one (1) carrier in every other panel, and a bottom guide pin traveling in a recessed floor guide channel (flush with finished floor) providing lateral stability to the glass wall panels.
- B. Moveable glass wall panels shall be extended / retracted utilizing specific type pull handles (1.57" [40]) strategically located on glass panels. (Refer to Part 2.05 "B. Pull Handle Finish".)

2.04 STACK ARRANGEMENTS

- A. Stack Type: Panel storage configuration shall be Offset Stack, consisting of panels stacked to one (1) side of the wall's installed position.
- B. Stack Quantity: Panels shall be stored at (select):
1. Standard One (1) End: on one (1) end of the wall run.
 2. Optional Both Ends: on both ends of the wall run.

2.05 FINISHES

- A. Hardware Finish: Panel hardware including horizontal rails shall be finished of (select):
1. Standard Finish: Clear Anodized Brushed Aluminum.
 2. Optional Finish: Custom Anodized
 3. Optional Finish: RAL Powder Coat
- B. Pull Handle Finish: Handle shall have a Stainless Steel Satin Effect finish.

2.06 PERIMETER TRIM AND SEALS

- A. Trim and Seals shall consist of (select):
1. Standard Trimless: consisting of 3/8" [10] tempered glass with a sanded / beveled edge, resulting in a minimal groove appearance between adjacent glass panels.
 2. Optional Horizontal Top and Bottom Brush Seals: consisting of continuous contact black nylon brush seals provided on both sides of each panel.

2.07 CLOSURE SYSTEMS

- A. Initial Closure System: The lead panel (the first panel exiting the stack) shall intersect vertically against a rigid wall surface or Fixed Pivot or Fixed Swing Panel, as accomplished by a lead panel that does not use any vertical jamb to affect initial closure, and shall contain a pull handle on both sides. (Refer to Part 2.05 "B. Pull Handle Finish".)
1. Optional Fixed Pivot Panel Closure (even number of moveable panels only): consisting of a panel utilizing top and bottom pivots allowing the panel to pivot and be used to affect final closure. Final closure panel shall contain a pull handle. (Refer

to Part 2.05 "B. Pull Handle Finish".)

2. Optional Fixed Swing Panel Closure (with even number of moveable panels only): consisting of a lead panel utilizing a top pivot and bottom pivot that engages with a self-closing unit containing a hold-open feature that is recessed flush into the floor allowing the panel to pivot 90° in both directions and providing access thru the moveable glass wall system when it is setup in the extended position. Both sides of the Fixed Swing Panel shall contain a pull handle. (Refer to Part 2.05 "B. Pull Handle Finish".)

Note: If optional Fixed Swing / Pivot Panel is selected, panel must be located at the end opposite the stack area.

- B. Final Closure System: The final closure panel (the last panel at the stack end) shall provide a method for affecting final closure of the moveable glass wall system. The final closure panel shall be a panel which has a top and bottom pivot that allows the panel to pivot and be used to affect final closure.

2.08 PANEL ACCESSORY

- A. Floor Guide Channel: Consisting of a clear anodized extruded aluminum channel that is recessed into the floor (flush with finished floor) to provide additional stability to panels as they are moved in and out of their storage location. Channel shall be compatible with bottom guide pin located at bottom of panels and shall be furnished by KWIK-WALL as noted on submitted shop drawings. (Optional on openings of two (2) panels or less. Standard on openings greater than two (2) panels.)

2.09 TRACK SYSTEM

- A. Aluminum Track: The VARIOFOLD track system shall be extruded of structural grade aluminum alloy, as engineered by HAWA®, and finished in anodized clear satin finish, which resists color fading and flaking.

2.10 CARRIER SYSTEM

- A. Carrier: Every other panel shall be top supported by one (1) carrier utilizing a $\frac{3}{8}$ " [10] diameter pendant bolt. Each carrier shall consist of four (4) permanently-lubricated, ball bearing steel wheels with high-density polymer tires as required for ease of panel movement.

2.11 SUSPENSION SYSTEMS

- A. Mounting Systems: The VARIOFOLD track system shall be supported by (select):
 1. Standard Drop Rod Bracket Mount: consisting of steel drop rod brackets with drop rods, consisting of adjustable rods of grade 2, $\frac{3}{8}$ " [10] diameter threaded steel all-rod provided with $\frac{3}{8}$ " [10] serrated steel nuts.
 2. Optional Direct Mount: consists of #16 x 3" [76] wood/metal screws for attachment to a level overhead structural (wood/steel) support.

3.01 INSPECTION

- A. Proper and complete preparation of the moveable glass wall system opening shall be by others in accordance with the architectural drawings, KWIK-WALL's shop drawings and ASTM E 557. Any deviation of the actual opening from these specifications shall be called to the attention of the architect prior to the installation of the moveable glass system.
- B. Deficiencies in the moveable glass wall opening shall be corrected by others prior to installation of the moveable glass wall system.

3.02 INSTALLATION

- A. The moveable glass wall system shall be installed by KWIK-WALL's authorized distributor.
- B. The moveable glass wall shall be installed in accordance with KWIK-WALL's written instructions, shop drawings and ASTM E 557 installation guidelines.

3.03 ADJUSTING AND CLEANING

- A. The moveable glass wall panels and track system shall be adjusted and cleaned in accordance with KWIK-WALL's written instructions.

3.04 PROTECTION

- A. The moveable glass wall panels shall be stored in the stacked (retracted) position prior to acceptance by the owner's representative.

3.05 DEMONSTRATION

- A. KWIK-WALL's authorized distributor shall demonstrate proper operation and explain proper and necessary maintenance requirements of the moveable glass wall system to the owner's representative.

VARIOFOLD PRODUCT SELECTION GUIDE

Model	Operation	Stack Arrangements	Glass	Perimeter Trim and Seals	Final Closure Options	Maximum Panel Height	Maximum Wall Width
Variofold	Continuously Hinged Panels	Offset Stack	Standard: Clear Optional: Etched, Decorated, Patterned or Berman editions	Trimless	Standard: Full Panel Top and Bottom Pivot *Optional: Fixed Swing / Pivot Panel	8'-6 ³ / ₄ " (2.61 m)	**17' - 8 ¹ / ₂ " (5.4 m)

*If Fixed Swing / Pivot Panel is used, panel must be located at the opposite end of the stack.

** Maximum Single Wall Width 17'-8¹/₂" (5.4 m). Maximum Bi-Stacking Wall Width is 35'-5" (10.8 m)

*** A maximum of six (6) panels may be used per side.

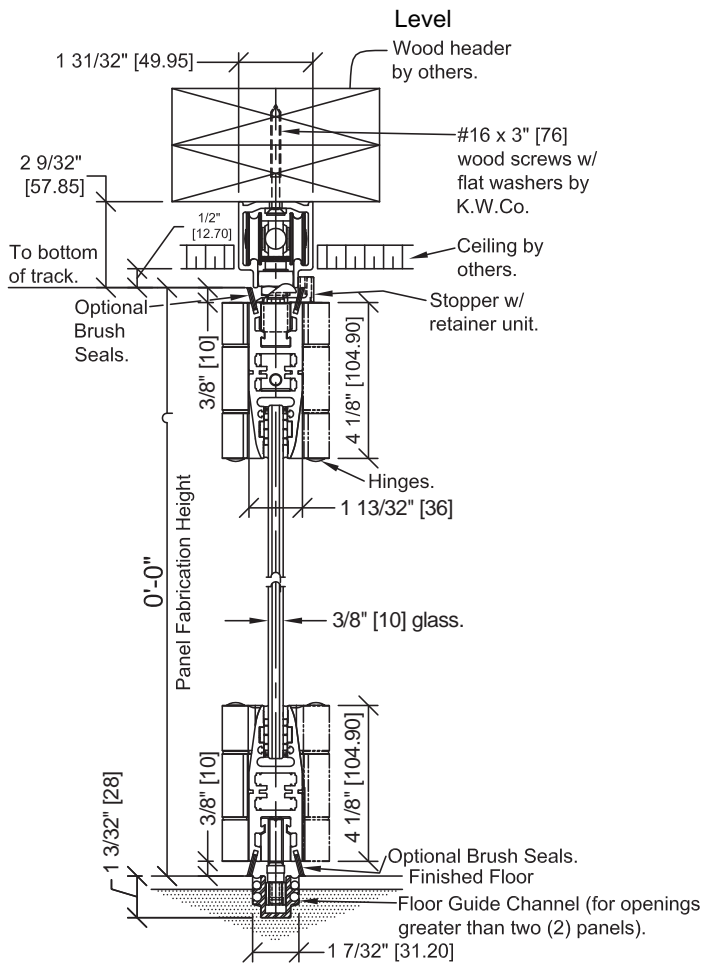

Direct Mount with Floor Guide and Brush Seals Variofold

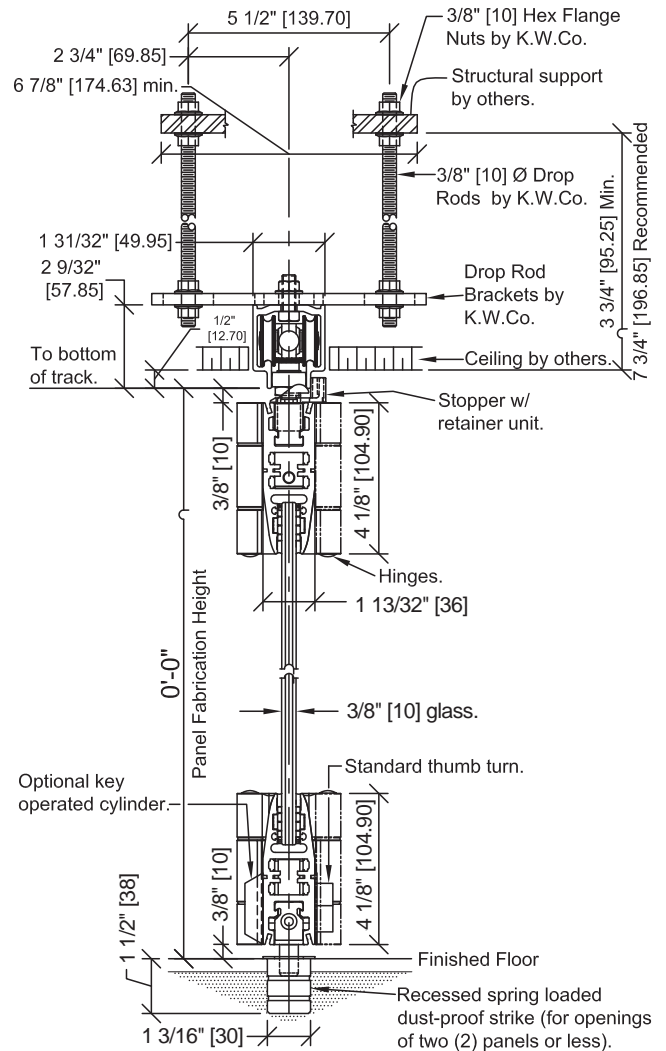

Drop Rod Bracket Mount Variofold

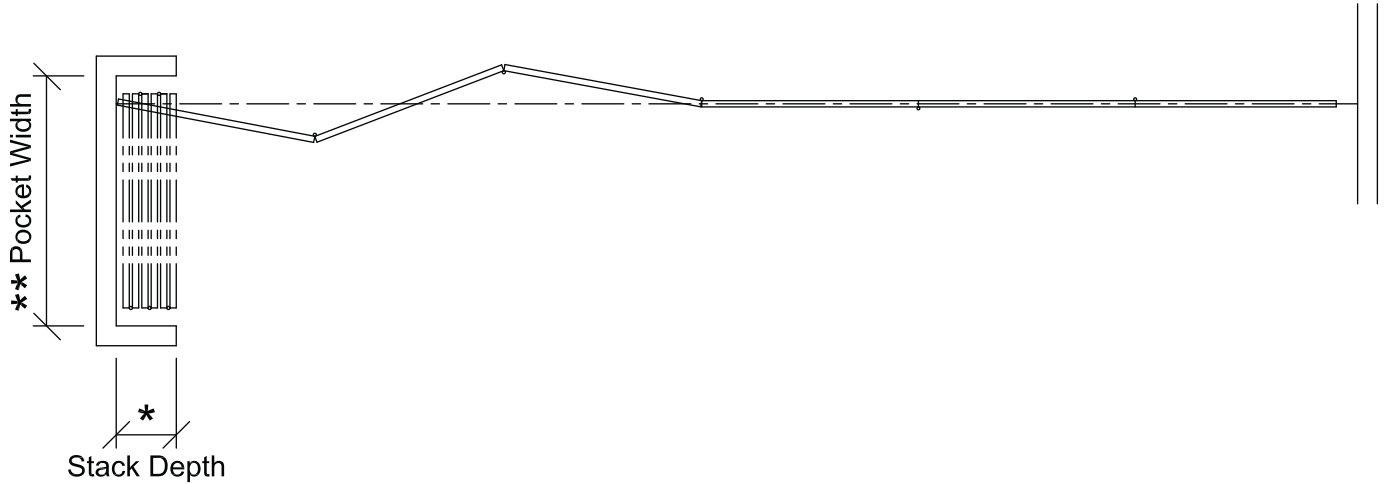

Standard Offset Stack

Panels shall be Offset Stacked, consisting of panels stacking perpendicular to the wall's installed position and offset to the left or right of the main track.

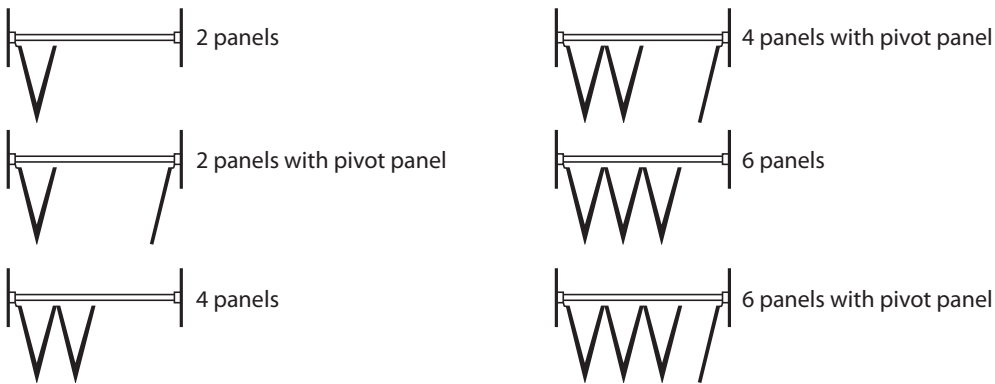

Stack Depth*

The overall depth of the stack area, as required for panel storage, is dictated by the total number of panels in the wall system. KWIK-WALL's Variofold panels require an average stack depth of 2³/₈" [60] per panel. To determine the stack depth, calculate as follows:

$$\text{Number of Panels} \times 2\frac{3}{8}" [60] + 2\frac{1}{8}" [54] + \frac{3}{4}" [18]$$

*Note: Additional stack depth is required for wall systems containing the following type of panels:

- Handle: 3¹/₂" [89]
- Pivot Panel(s) Closure: 2³/₈" [60]
- Pocket Door(s): 6" [152]

Pocket Width**

The width of the pocket is determined by the widest panel in the wall run. For specification purposes, assume the widest panel is 2'-11⁷/₁₆" (90 cm) maximum. Pocket width may be calculated as follows:

$$\text{Panel Width} + 7" [178]$$

(allows 3¹/₂" [89] for hand clearance on each side)

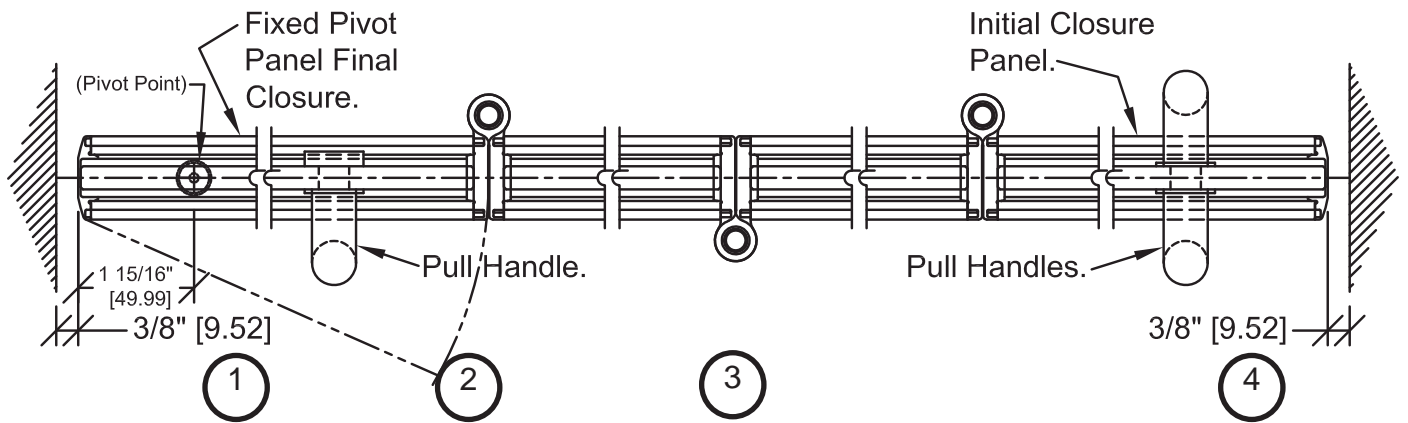

HORIZONTAL DETAIL VARIOFOLD TRIMLESS

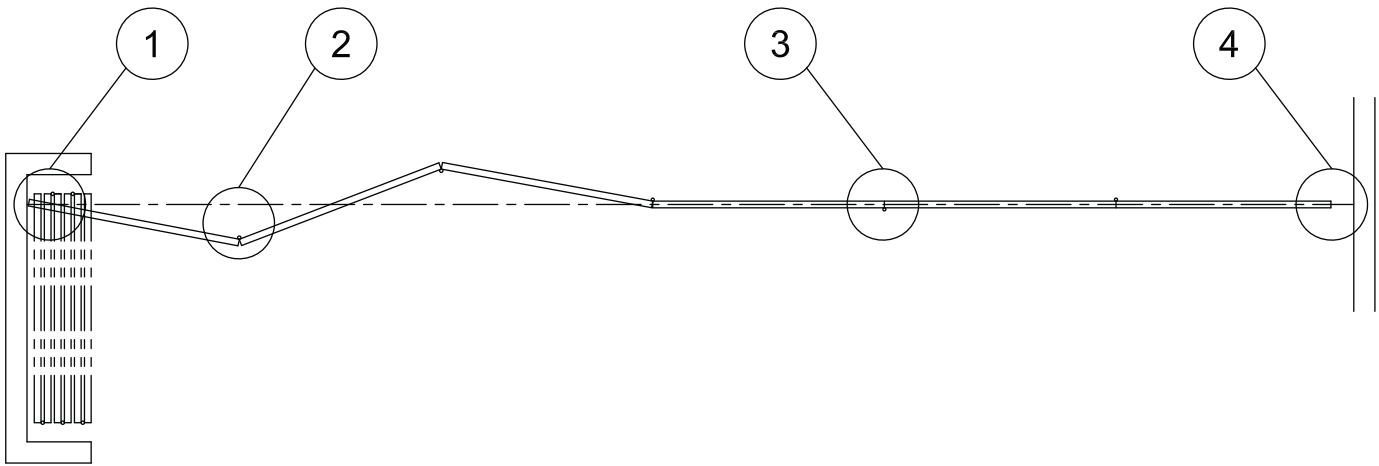

1. Fixed Pivot Panel Closure
2. Typical Joint
3. Typical Joint
4. Initial Closure panel

Horizontal details for numbers 1 through 4 can be found on page 8

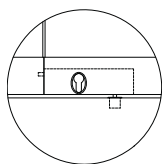
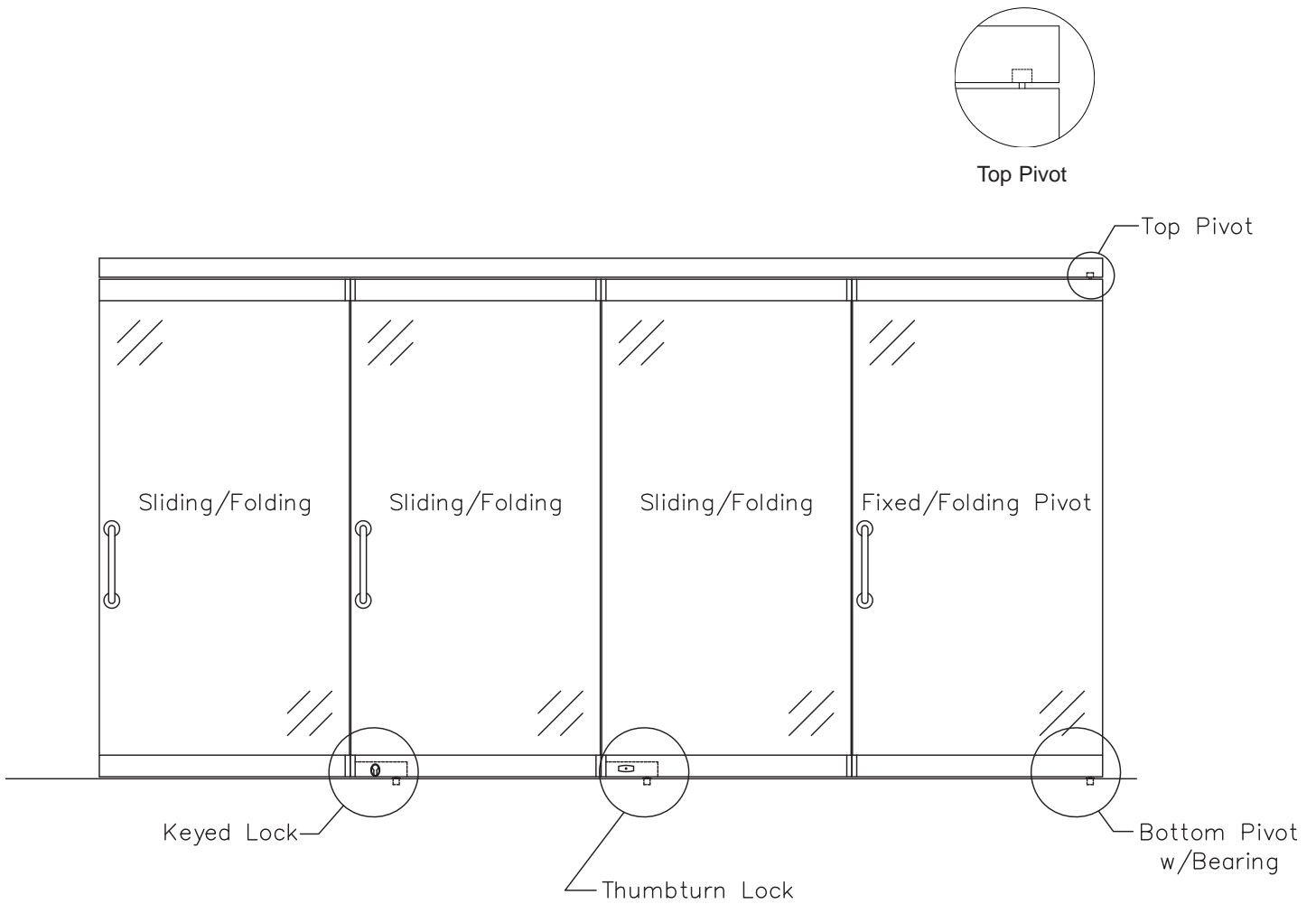

Keyed Lock

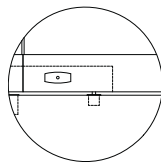

Thumbturn Lock

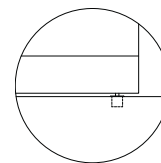

Bottom Pivot w/Bearing

KWIK-WALL offers a full complement of accessories for customizing any glass wall system to meet the specific needs of the most demanding project.

If you don't see the style or options and accessories you are looking for, KWIK-WALL has many other styles of Operable Glass Walls to bring you the solution to your space division needs.

The Product Selection Guide will step you through the various features of each model. Product stack arrangements and details show the more common elements for each model.

Model	APPLICATIONS		PRODUCT FEATURES						
	Interior	Exterior	Pivot Door	Sliding Pivot Panel	Sliding Swing Panel	Color Options	Trimmed Vertical Edge	Trimless Vertical Edge	Lock Options
Variotec	✓		✓	✓	✓	✓	✓	✓	✓
Cornertec	✓		✓			✓		✓	✓
Variofold	✓		✓			✓		✓	✓
Centerfold	✓		✓			✓		✓	✓
Aperto	✓		✓			✓		✓	✓
KWV-Tec	✓		✓			✓	✓	✓	✓
KWP-Fold	✓		✓			✓		✓	✓

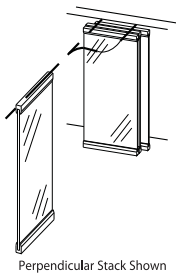

Individual Panels - Perpendicular, Parallel, Remote or Custom Stack (Aperto, Variotec, Cornertec & KWV-Tec)

Individual Panels are top supported by two (2) carriers that operate in the track system that allows panels to move and turn effortlessly through radius intersections that are engineered for heavy glass panels. The versatility of stack arrangements includes Perpendicular Stack, Parallel Stack, Remote or Custom Stack.

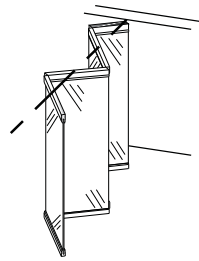

Continuously Hinged Center Stack (Centerfold)

Continuously Hinged Panels are hinged together to form a continuous panel train that allows for easy set-up. The Center Stack arrangement provides panel storage at one or both ends of the wall's installed position. The final closure panel is a half panel.

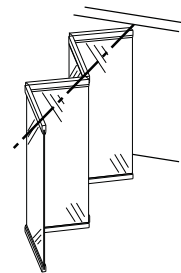

Continuously Hinged - Offset Stack (Variofold)

Continuously Hinged Panels are hinged together to form a continuous panel train that allows for easy set-up. The Offset Stack System allows panels to be stacked perpendicular to the main track & offset to the right or left.

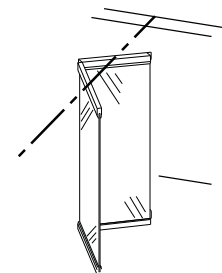

Hinged Pairs Center Stack (KWP-Fold)

Hinged Pairs Panels are panels hinged together in groups of two (2), unless otherwise specified. Panels are top-supported by one (1) carrier in each panel. The Center Stack arrangement provides panel storage at one or both ends of the wall's installed position.

VARIOFOLD GLASS WALL LIMITED WARRANTY

KWIK-WALL Company warrants each glass wall and its component parts to be free from defects in material and workmanship for a period of two (2) years from date of delivery to the original purchaser, when installed by an authorized KWIK-WALL distributor. KWIK-WALL Company reserves the right to have authorized personnel inspect any part alleged to be defective and to refuse any returned material unless the return was previously authorized by KWIK-WALL. (Glass is specifically excluded from the warranty.)

This warranty does not apply to any damage or deterioration caused by abuse or failure to provide reasonable and necessary maintenance. All field applied finishes, accessories or product modifications are specifically excluded under this warranty. KWIK-WALL's liability hereunder is limited to the replacement of any partition or component part found to be defective. Labor charges are the responsibility of the customer.

KWIK-WALL SHALL NOT BE LIABLE FOR ANY INCIDENTAL OR CONSEQUENTIAL DAMAGES. ALL OTHER WARRANTIES EXPRESSED OR IMPLIED INCLUDING ANY IMPLIED WARRANTY OF MERCHANTABILITY ARE HEREBY EXPRESSLY EXCLUDED.

Some states do not allow the exclusion or limitation of consequential or incidental damages, so the above limitation or exclusion may not apply to you.

This warranty gives you specific legal rights, and you may also have other rights which vary from state to state

Note:

Due to ongoing research and development, some variation may occur in product specifications and design. Please refer to your actual KWIK-WALL shop drawing(s) for exact product dimensions and specifications.

Distributed By:

